

1500 GPM MINI PUMPER #2476

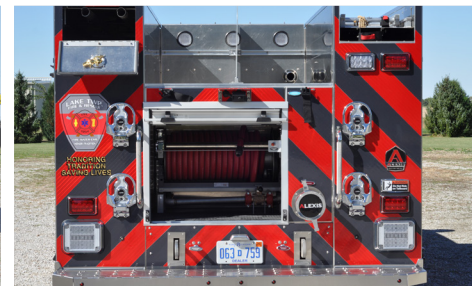

TECHNICAL SPECIFICATIONS

- Ford F-550 4x4 Super Duty Crew Cab Chassis
- 6.7L 4V OHV V8 Turbo Diesel Engine
- TorqShift 10-Speed Automatic Transmission
- Heavy Duty Stainless Steel Body and Stainless Steel Subframe
- Stainless Steel Pump Panel in L1/R1 with Stainless Steel Subframe
- N-Fab Podium Black Cab Side Steps
- Go Industries Brush Guard with Hitch and Rear Hitch with Winch Wiring
- Warn Zeon 10 Multi-Mount Winch
- Hale DSD 1500 GPM Split Shaft Pump with Hale ESP Priming Pump
- FRC PumpBoss Pressure Governor
- FRC TankVision Water Tank Level Gauge
- Two (2) 6" Intakes, One (1) Each Side
- One (1) 5" Rear Intake, Adapted to 6" NSTM
- One (1) 2½" Gated Intake Left Side
- Two (2) 2½" Discharges, Left Side, One (1) 2½" Discharge, Right Side
- One (1) 3" Discharge Adapted to 5" Storz, Right Side
- One (1) 2½" Discharge, Front of Hose Bed on the Right Side
- One (1) 3" Deck Gun Discharge
- Two (2) 1½" Cartridge Lay Preconnect, L1/R1 Compartments
- One (1) Booster Reel Rear Compartment with 100' of 1" Hose
- Three (3) Single Wheel Well Air Bottle Compartments
- ROM Painted Roll-Up Doors
- 300 Gallon Poly Tank
- 12 Volt Electrical System with NFPA Compliant Warning Light Package
- Progressive Dynamics Charger with Viar Compressor and Auxiliary Air Tank
- Kussmaul 120V 20A Super Auto Eject, Left Side Rear Wheel Well
- Tecniq LED Warning and LED Scene Light Package
- Whelen Electronic Siren & 100W Speaker
- FireTech HiViz 21" LED Brow Light Mounted on the Brush Guard
- Hard Suction Storage Left Side and Ladder Storage Right Side
- One (1) 10' Attic Ladder and One (1) 16' 2-Section Ladder
- 8' Overall Height
- 26'-10" Overall Length
- 203.8" Wheelbase
- 84" Cab to Axle
- 7,500 FAWR
- 14,700 RAWR
- 19,500 GVWR



CUSTOMER APPROVAL SIGNATURE: _____ DATE: _____

APE-2476

IN THE EVENT THERE ARE DISCREPANCIES BETWEEN THE DRAWING AND THE SPECIFICATIONS THE SPECIFICATIONS SHALL PREVAIL.

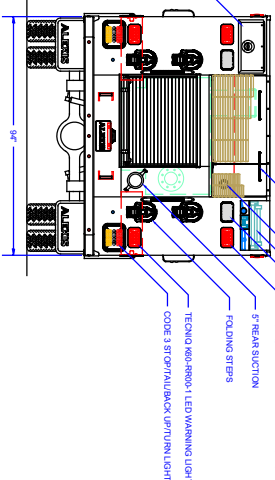
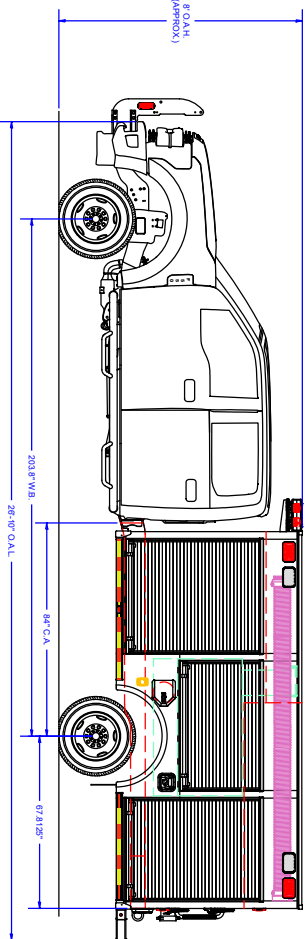
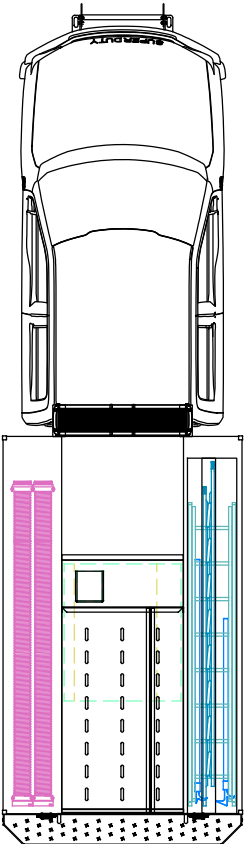
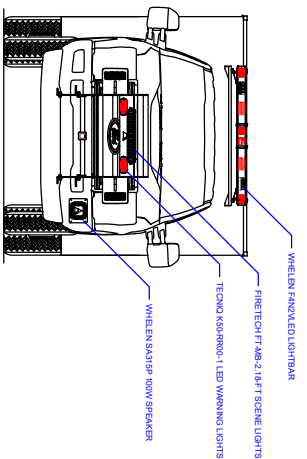
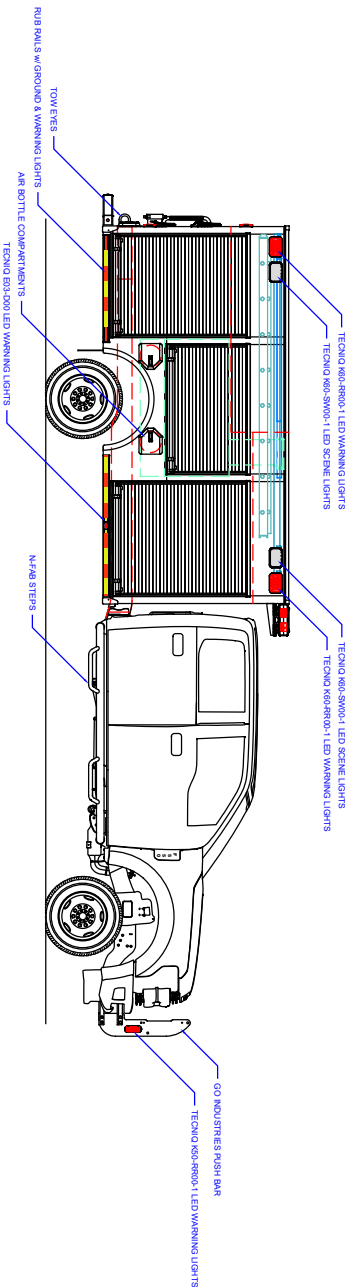

COMPARTMENT DIMENSIONS

COMP. #	DOOR OPENING SIZES
L1 & R1	43" WIDE X 48" HIGH X PLUMP PANEEL
L2 & R2	49" WIDE X 27" HIGH X 21" DEEP
L3 & R3	38" WIDE X 48" HIGH X 21" DEEP
REARS	34" WIDE X 25" HIGH X 41" DEEP

Pump Info:		Apparatus Type:	Mini Pumper
Control Location:	Side	Chassis:	Ford 4-Door
Pump Drive:	Split Shaft	Tank Capacity:	300
Pump Make:	Hale	Material:	Stainless Steel
Pump Model:	DS2		
Pump GPM:	1500		

REV	DESCRIPTION	DATE	DRAWN	DATE	CHECKED
01	REVISED APPROVALS	10/2/23	WKL	10/2/23	MS

ALEXIS FIRE EQUIPMENT CO.
P.O. BOX 169, ALEXIS, ILLINOIS 62412

MINI PUMPER M2
LAKE CHARTRER TOWNSHIP
BRIDGEHAM, MI

SIZE CODE: 11/1922
D 1/2" = 1"
CONTROL # 1 2476

UNLESS OTHERWISE SPECIFIED
DIMENSIONS ARE IN INCHES
TOLERANCES ARE NOT TO EXCEED ±.015"
FRACTIONAL DIMENSIONS ARE TO THE NEAREST .015"

The copyright of this drawing and design
and the right of reproduction here, is held
by Alexis Fire Equipment Co.
M. TINKHAM
11/1922
D 1/2" = 1"
CONTROL # 1 2476

SHEET 1 OF 2