

REVISION HISTORY				Pump Info:		COMPARTMENT DIMENSIONS	
REV	DESCRIPTION	DATE	DWN	Control Location: Side	Apparatus Type: Pumper/Tanker	COMP #	DOOR OPENING SIZES
				Pump Drive: PTO	Chassis: INTERNATIONAL HV607 2-DOOR	L1 & R1	61" WIDE X 31" HIGH X 25" DEEP
				Pump Make: Waterous	Tank Capacity: 2000	L2 & R2	27" WIDE X 31" HIGH X 25" DEEP
				Pump Model: CXVPA	Material: Aluminum		
				Pump GPM: 1250			

UNLESS OTHERWISE SPECIFIED DIMENSIONS ARE IN INCHES TOLERANCES ARE NOT CUMULATIVE
 DECIMAL ±0.062 ANGULAR ±0.5° FRACTIONAL ±1/16 METRIC ±1.6 mm

ALEXIS FIRE EQUIPMENT CO.
 P.O. BOX 549, ALEXIS, ILLINOIS 61412

DRY SIDE TANKER
 ALEXIS FIRE EQUIPMENT CO
 ALEXIS, IL

The copyright of this drawing and design and the right of reproduction there is vested in and belongs to Alexis Fire Equipment Co.

DRAWN: M. TINKHAM 3/18/24 SIZE: D SCALE: 1/2" = 1' DWG NO: P-AB67

MATERIAL: _____ CONTRACT #: _____ SHEET 1 OF 2

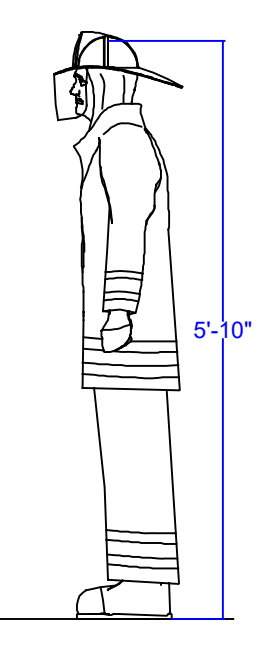
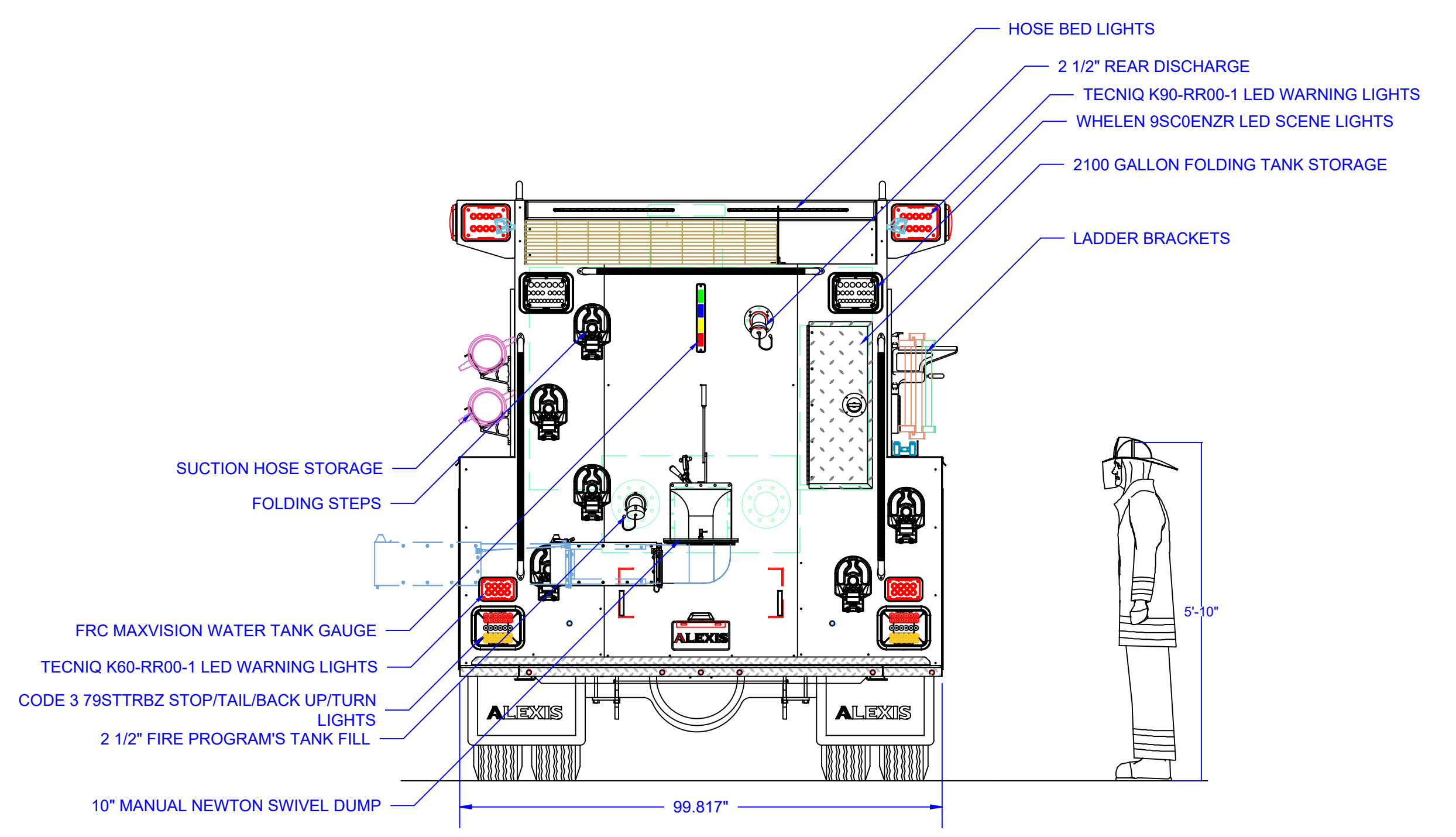
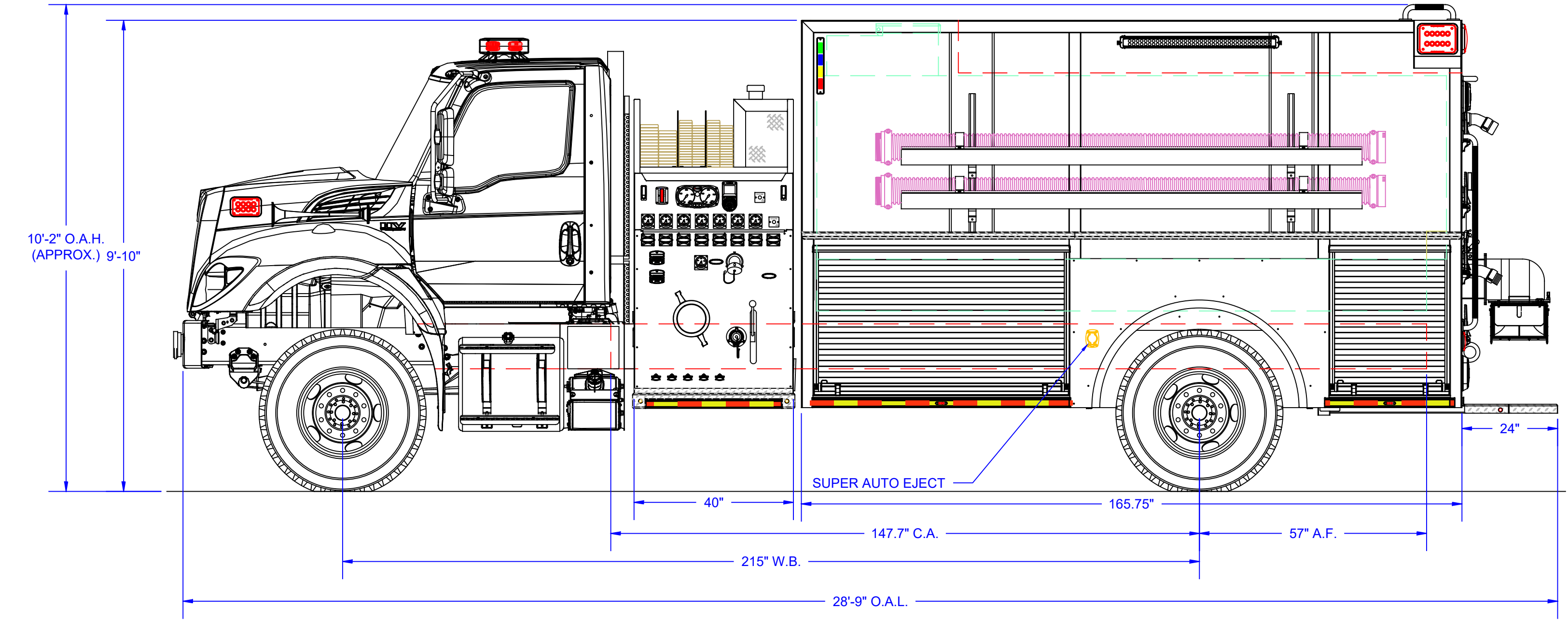
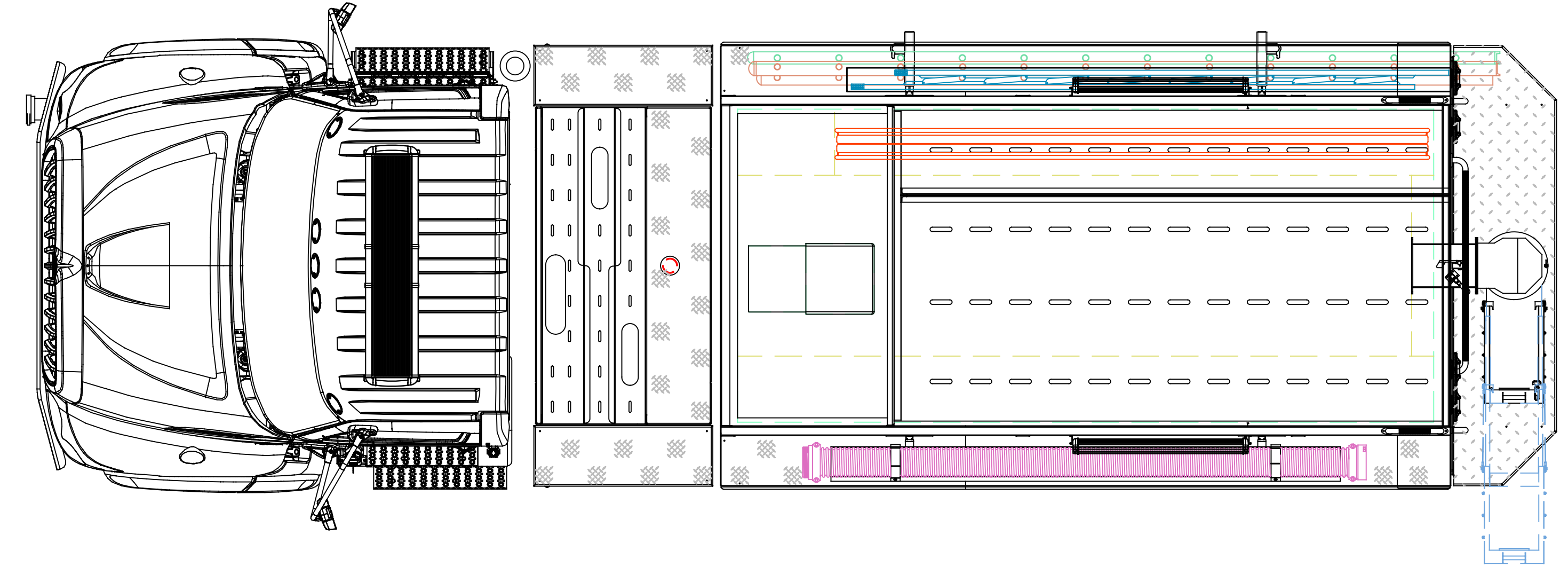
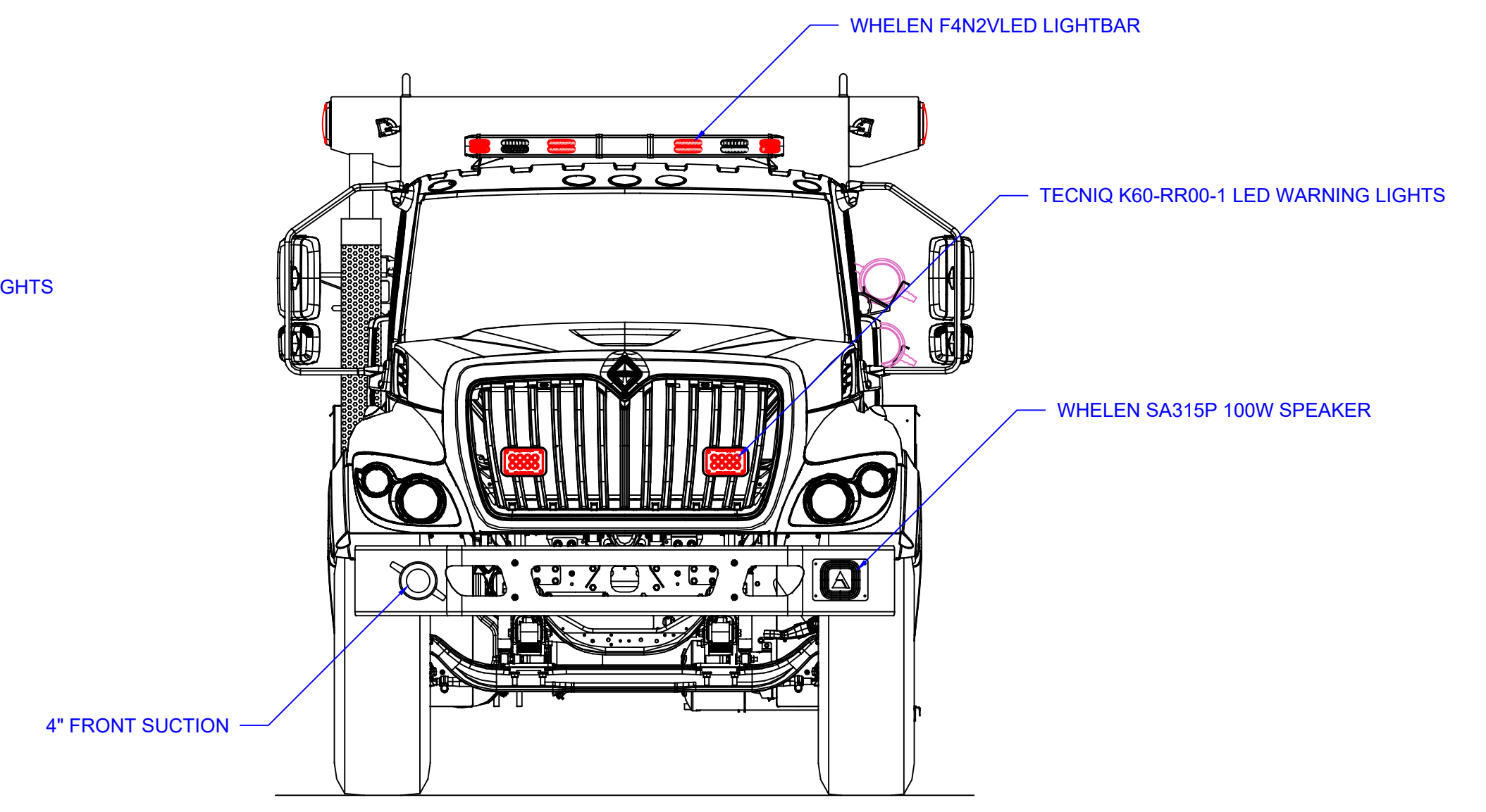
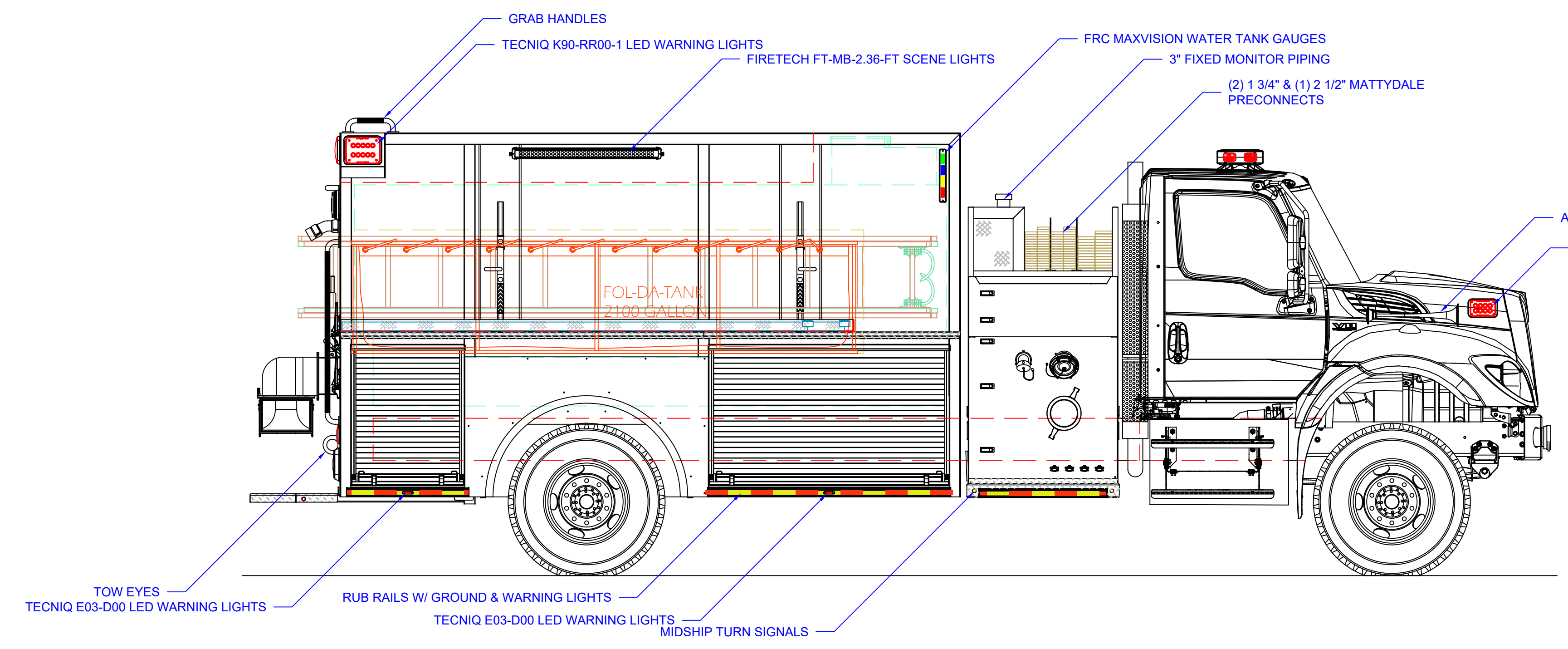

REVISION HISTORY			
REV	DESCRIPTION	DATE	DWN

Pump Info:	Apparatus Type: Pumper/Tanker
Control Location: Side	Chassis: INTERNATIONAL HV607 2-DOOR
Pump Drive: PTO	Tank Capacity: 2000
Pump Make: Waterous	Material: Aluminum
Pump Model: CXVPA	
Pump GPM: 1250	

COMPARTMENT DIMENSIONS	
COMP #	DOOR OPENING SIZES
L1 & R1	61" WIDE X 31" HIGH X 25" DEEP
L2 & R2	27" WIDE X 31" HIGH X 25" DEEP

UNLESS OTHERWISE SPECIFIED DIMENSIONS ARE IN INCHES TOLERANCES ARE NOT CUMULATIVE
 DECIMAL ± 0.062 ANGULAR ± 0.5° FRACTIONAL ± 1/16 METRIC ± 1.6 mm

ALEXIS FIRE EQUIPMENT CO.
 P.O. BOX 549, ALEXIS, ILLINOIS 61412

DRY SIDE TANKER
 ALEXIS FIRE EQUIPMENT CO
 ALEXIS, IL

The copyright of this drawing and design and the right of reproduction there is vested in and belongs to Alexis Fire Equipment Co.

DRAWN M. TINKHAM	DATE 3/18/24	SIZE SCALE D 1/2" = 1'	DWG NO P-AB67
MATERIAL	CONTRACT #	SHEET 1 OF 2	



 Alexis Fire Equipment
 109 East Broadway / Alexis, IL 61412
 800-322-2284  sales@alexisfire.com
 AlexisFire.com

Alexis Fire Equipment Company
Alexis, IL

We hereby propose to furnish, after your acceptance, approval, and proper execution of the accompanying contract, the fire apparatus as follows:

One (1) Alexis Demo #2642 2000 Gallon Tanker

As per specifications attached herewith.

TOTAL APPARATUS.....\$ *

* Does not include any applicable taxes. Any local or state tax, if applicable, must be added to the above price.

Shipment of completed apparatus shall be made within 550 calendar days after our approval of properly signed contract, subject to causes beyond our control. This proposal is made subject to your acceptance within thirty (30) days from date of same. If acceptance is delayed beyond that period, we will, upon request, advise you of any increase in said amount which may be occasioned by causes beyond our control.

Respectfully submitted,
ALEXIS FIRE EQUIPMENT COMPANY

By: _____

"QUALITY HAS NO SUBSTITUTE"



 Alexis Fire Equipment
109 East Broadway / Alexis, IL 61412
 800-322-2284  sales@alexisfire.com
 AlexisFire.com

PAYMENT TERMS

The chassis payment shall be made within ten (10) days of invoicing.

A progress payment of \$ shall be made within ten (10) days of invoicing, upon the initial construction of the apparatus body. The ___ Fire Department may **DEDUCT \$** from the front page price for this payment.

The balance of the contract plus any contract alterations shall be payable upon the delivery of the finished unit.

Upon payment, the Alexis Fire Equipment Company shall furnish the purchaser a "Statement of Origin" or the necessary validated documents required for title application.

Additional payment terms available upon request.



 Alexis Fire Equipment
109 East Broadway / Alexis, IL 61412
 800-322-2284  sales@alexisfire.com
 AlexisFire.com

ISO 9001:

Alexis Fire Equipment Company operates a Quality Management System under the requirements of ISO 9001. These standards, sponsored by the "International Organization for Standardization (ISO)," specify the quality systems that shall be established by the manufacturer for design, manufacture, installation and service.



SERVICE CENTER:

The Alexis Priority-One service team is staffed with factory trained mechanics ready to meet your service requirements. Our staff is continually working on maintaining updated EVT and ASE certification.

The Alexis Service Team is available 24 hours a day, 7 days a week for your service emergencies. We use the latest paging system for fast, efficient and reliable service.

Our service facility covers an area of approximately 14,000 square feet.

The Alexis Service Team can assist you in fire apparatus service, ambulance service, aerial device maintenance, generator and rescue tool maintenance and service, and air pack inspections. Our staff can provide our customers with a complete apparatus training program, meeting the latest training requirements.

Alexis is a single source warranty center for the following manufacturers: Spartan Motors, Darley, Hale, and Waterous.

Our service team has over 50 years of cumulative experience in the fire service industry. In addition, they are backed by our fabrication, electrical, and paint and finish departments. This combination of training and hands-on experience offers true reliability and dependability.

Alexis keeps detailed documentation of all repair, maintenance, and inspection performed by our personnel. With time and manpower at such a premium among many fire departments, why not allow the Alexis Service Team to set up and maintain records for your fleet?

The Alexis Service Team is committed to providing prompt and courteous service, quality products and fair pricing.

Business: Alexis Fire Equipment Company
Location: 109 East Broadway Alexis, IL 61412
Phone: 800-322-2284



 Alexis Fire Equipment
109 East Broadway / Alexis, IL 61412
 800-322-2284  sales@alexisfire.com
 AlexisFire.com

DELIVERY:

The finished apparatus shall be picked up by the dealer organization at the plant site of the Alexis Fire Equipment Company in Alexis, Illinois.

To insure proper break-in of all drive train components while under warranty, the finished apparatus shall be delivered to the purchaser under its own power.

The apparatus shall be covered by comprehensive and liability insurance during the delivery period. The purchaser shall assume the insurance obligation on acceptance, and at that time shall present to the manufacturer's agent a certificate of verification, showing liability, comprehensive and collision insurance coverage.



GENERAL INFORMATION:

LOCATION

The Alexis Fire Equipment facilities are located at 109 East Broadway, Alexis, Illinois 61412. We maintain a complete stock of parts and services available around-the-clock. We also propose to maintain parts and service for a minimum period of twenty (20) years on all apparatus which is manufactured.

NOTATION

To further assure the customer of our ability to manufacture quality fire apparatus, we are proud of the fact that Alexis Fire Equipment Company is family-owned and has been in the fire apparatus business since 1947. All apparatus manufactured by Alexis Fire Equipment are designed and built to meet the requirements of the latest edition of NFPA 1901.

PERSONNEL CAPACITIES

To meet the spirit of N.F.P.A. 1500 paragraph 6.3.1, this apparatus has been designed to transport not more than two (2) people.

6.3 Riding in Fire Apparatus

6.3.1 All persons riding in fire apparatus shall be seated and belted securely to the vehicle by seat belts in approved riding positions and at any time the vehicle is in motion. Standing or riding on tailsteps, sidesteps, running boards or in any other exposed position shall be specifically prohibited.

MAXIMUM TOP SPEED:

To meet the intent of NFPA 1901 4.15.3, the top speed of the vehicle shall not exceed 60 MPH or the manufacturer's maximum fire service speed rating for the tires installed on the apparatus, whichever is lower.

INFORMATION TO BE PROVIDED:

Alexis Fire Equipment Company shall supply, at the time of delivery, the following documents:

- A) The manufacturer's record of apparatus construction details, including the following information:
1. Owner's name and address
 2. Apparatus manufacturer, model, and serial number.
 3. Chassis make, model, and serial number.
 4. GAWR of front and rear axles.
 5. Front tire size and total rated capacity in pounds.
 6. Rear tire size and total rated capacity in pounds.
 7. Chassis weight distribution in pounds with water and manufacturer mounted equipment.
 8. Engine make, model, serial number, number of cylinders, bore, stroke, displacement and compression ratio, rated horsepower and related speed, and no-load governed speed.
 9. Type of fuel and fuel tank capacity.
 10. Electrical system voltage and alternator output in amps.
 11. Battery make and model, capacity in CCA.
 12. Transmission make, model, and type.
 13. Pump to drive through the transmission (yes or no)
 14. Engine to pump gear ratio used
 15. Pump make, model, rated capacity in g.p.m., serial number, number of stages, and impeller diameter in inches.
 16. Pump transmission make, model, and serial number.
 17. Priming device type.
 18. Type of pump pressure control system.
 19. Auxiliary pump make, model, rated capacity in g.p.m., serial number, number of stages, and impeller diameter in inches.
 20. Water tank certified capacity in gallons.
 21. Aerial device type, rated vertical height in feet, rated horizontal reach in feet, and rated capacity in pounds.
 22. Paint numbers
 23. Company name and signature of responsible company executive.
- B) If the apparatus has a fire pump, the pump manufacturer's certification of suction capability.
- C) If the apparatus has a fire pump, a copy of the apparatus manufacturer's approval for stationary pumping applications.
- D) If the apparatus has a fire pump, the engine manufacturer's certified brake horsepower curve for the engine furnished, showing the maximum no-load governed speed.
- E) If the apparatus has a fire pump, the pump manufacturer's certification of hydrostatic test.
- F) If the apparatus has a fire pump, the certification of inspection and test for the fire pump.
- G) If the apparatus has an aerial device, the certification of inspection and test for the aerial device.
- H) If the apparatus has an aerial device, all the technical information required for inspections to comply with NFPA.
- I) Weight documents from a certified scale - showing actual loading on the front axle, rear axle(s), and

overall vehicle (with the water tank full but without personnel, equipment, and hose) - shall be supplied with the completed vehicle.

- J) Written load analysis and results of the electrical system performance tests.
- K) If the apparatus is equipped with a water tank, the certification of water tank capacity.
- L) If the apparatus has a fire pump, two (2) copies of the pump operation and maintenance manual.
- M) Two (2) destination effective wiring diagrams.
- N) Copies of electrical and mechanical component manuals for equipment purchased on or with the apparatus.
- O) A sketch of the booster tank indicating all dimensions and baffle locations.
- P) If the apparatus has a pump, one (1) certification of third party test

WARRANTY:

Alexis Fire Equipment Co., Inc. warrants each new piece of Ashland Series fire and rescue apparatus to be free from defects in material and workmanship under normal use and service. Our obligation under this warranty is limited to repairing or replacing, as the company may elect, any part or parts thereof which shall be returned to us with transportation charges prepaid, and as to which examination shall disclose to the company's satisfaction to have been defective, provided that such part, or parts shall be returned to us not later than one year after delivery of such vehicle. Such defective part or parts will be repaired or replaced free of charge and without charge for installation to the original purchaser. All water tanks will be warranted as stated herein and may have extended warranty as explained elsewhere in the Alexis Fire Equipment Co. Proposal.

This warranty will not apply:

1. To normal maintenance service or adjustments.
2. To any vehicle which shall have been repaired or altered outside of our factory, in any way so as, in our judgement, to affect its stability, nor which has been subject to misuse, negligence, or accident, nor to any vehicle made by us which shall have been operated at a speed exceeding the factory rated speed, or loaded beyond the factory rated load capacity.
3. To the chassis and associated equipment furnished with chassis, signaling device, generators, batteries or other trade accessories. These are usually warranted separately by their respective manufacturers.
4. To work performed by an outside service without prior authorization obtained from Alexis Fire Equipment.
5. To costs incurred from an outside service for non-warranty related items.



This warranty is in lieu of all other warranties, expressed or implied, and all other representations to the original purchaser and all other obligations or liabilities, including liability for incidental or consequential damages on the part of the company. We neither assume or authorize any other person to give or assume any other warranty or liability on the company's behalf unless made or assumed in writing by the company.

LENGTH AND/OR HEIGHT LIMITATIONS:

OVERALL HEIGHT:

There shall be no overall height restrictions.

OVERALL LENGTH:

There shall be no overall length restrictions.

CHASSIS MODIFICATIONS:

STEP ASSEMBLIES:

The step assemblies on the left and right side of the chassis shall remain as specified in the chassis specifications.

MUD FLAPS:

Each rear fender shall be extended with a black rubber mud flap, thus preventing splash and road debris from damaging the apparatus body.

CHASSIS SUPPLIED WHEELS:

The wheel finish on the apparatus shall be left as specified in the chassis specifications.

LABELS:

A permanent plate in the driving compartment shall specify the quantity and type of the following fluids used in the vehicle:

- Engine Oil
- Engine Coolant

- Chassis Transmission Fluid
- Pump Transmission Lubrication Fluid
- Pump Primer Fluid (if applicable)
- Drive Axle(s) Lubrication Fluid
- Air-Conditioning Refrigerant
- Air-Conditioning Lubrication Oil
- Power Steering Fluid
- Cab Tilt Mechanism Fluid
- Transfer Case Fluid
- Equipment Rack Fluid
- CAFS Air Compressor System Lubricant
- Generator System Lubricant
- Front Tire Cold Pressure
- Rear Tire Cold Pressure
- Maximum Tire Speed Ratings

A final manufacturer's certification of the GVWR or GCWR along with a certification of each GAWR, shall be supplied on a label affixed to the vehicle.

A sign that reads "Occupants Must Be Seated and Belted When Apparatus Is in Motion" shall be provided. The sign shall be visible from each seated position.

A label that states the number of personnel the vehicle is designed to carry shall be located in an area visible to the driver.

A sign stating the overall height of the vehicle in feet and inches, the overall length of the vehicle in feet and inches, and the GVWR in tons shall be provided and mounted. The sign shall be visible to the driver of the vehicle while seated.

A label stating "Do Not Wear Helmet While Seated" shall be visible from each seating position.

A label stating "All Equipment Stored in the cab shall be properly secured" shall be visible from each seating position.

A "Do Not Ride" label shall be visible near all stepping and standing surfaces

HELMET STORAGE:

To meet the intent of NFPA 14.1.8.4.1, the helmet for each occupant shall be stored in an exterior compartment.



PUMP AND PIPING:

PTO PUMP:

MANUFACTURER: Waterous.
MODEL: CXVPA 1250

CAPACITY: 1250 gpm. @ 150 psi.
SUCTION SIZE: 6" NST

PUMP SPECIFICATIONS

CASING:

Two piece, vertically split, high tensile, close grained gray iron.

IMPELLER:

Bronze impeller specifically designed for the fire service, double hubbed to eliminate axial thrust, and accurately balanced for vibration free running. Impellers with flame plated hubs for extreme wear resistance are optional.

WEAR RINGS:

Replaceable bronze wear rings to increase pump life and keep maintenance costs at a minimum.

IMPELLER SHAFT:

Stainless steel, heat treated, precisely ground to size, and polished under shaft seal. Supported by oil lubricated ball bearings.

BEARINGS:

All bearings are oil or grease lubricated, ball type, located outside the pump casting to accurately align and support the impeller shaft assembly. Ball bearings are deep groove type designed to carry both radial and axial thrust.

SHAFT SEAL:

Face type, self adjusting, corrosion and wear resistance mechanical seal is standard.

GEARS:

Crown shaved, carburized and hardened gears are constant mesh, helical design, for quiet operation and long life.

PIPING:

The piping will be stainless steel material throughout the waterway system. The suction waterway shall be 6" 304 stainless steel material. The suction waterways shall be designed to flow a minimum of 17% in excess of the rated capacity from draft. The suction piping shall incorporate a 4" suction inlet to allow for full flow from the tank valve assembly. The suction piping shall be adapted from 6" TIPT to NST with a chrome adapter. Each suction arm shall incorporate a Class 1 long handle cap. The suction system shall be designed with 6" victaulic couplings to allow ease of access for maintenance or removal of the pumping system.

The discharge system shall incorporate a 4" x 6" stainless steel distribution system. The manifold shall be fed from the 4" piping system. The discharge system shall incorporate a 4" victaulic system to allow ease of access for maintenance or removal of the pumping system. Each discharge shall be fed from above the manifold system.

PRIMING PUMP:

The priming pump shall be a Trident Emergency Products compressed air powered, high efficiency, multi-stage, venturi based AirPrime™ System. All wetted metallic parts of the priming system are to be of brass and stainless steel construction. A single panel mounted control will activate the priming pump and open the priming valve to the pump. The priming system shall have a five year warranty.

ADDITIONAL PRIMER CONTROL:

One (1) additional primer control valve shall be furnished to prime the specified auxiliary inlet individually. The Trident Emergency products RPV (remote priming valve) shall activate using the same air that powers the AirPrime™ system when the coinciding panel valve is depressed. Priming the remote suction line evacuates air from that line and minimizes cavitation during remote suction operations. The valve control is to be co-located next to the main priming valve control on the pump operator's panel.

AUXILARY INLET: Front Intake

DRIVELINES:

The PTO pumping system drivelines shall be manufactured by the apparatus manufacturer. The drivelines shall be professionally balanced by the apparatus manufacturer to ensure complete system balance.

6" SUCTION:

One (1) 6" NST suction shall be located on each side of the apparatus body. The suctions shall be open and not gated. An inlet screen and a 6" handle cap shall be included.

STEAMER GATES:

One (1) Elkhart EB6D butterfly valve(s) shall be installed in the specified suction inlet(s) of the pump. The valve shall have a ductile iron body with aluminum/bronze disk and EPDM seat. The valve shall be pressure rated to 250psi with a Cv Value of 1950. The valve shall be capable of bi directional flow. The valve shall not require lubrication of seats or any internal waterway components, and must be capable of swinging out of the waterway for maintenance. The valve shall carry a 10-year manufacturer's warranty. This valve shall be operated using an electric gear drive actuator. The actuator shall be quickly adjustable to one of four positions. The clutchless electric drive shall open or close the valve in no less than 5 seconds.

A warning label stating "**Warning: serious injury or death could occur if inlet is supplied by a pressurized source when the valve is closed**" shall be supplied and mounted.

APEX-S VALVE CONTROLLER

An Elkhart Brass APEX-S Electric Valve Controller shall be provided. The controller shall be no greater than 3.75" wide. The controller shall be rated to IP67 and operate the electric valve from a supply voltage of 12-24 VDC. Controller shall have CAN network capability. Valve position shall be monitored via true position feedback and displayed by 10 LED position indicators. The controller shall include OPEN/CLOSE buttons, a one-touch programmable preset valve position and auto-open/auto-close function. The controller shall include a top-mounted changeable visor available in colors to match the discharge.

Product Features

- Valve control with 10 segment LEDs for position indication
- CAN network compatible
- Oversized buttons for easy gloved-hand operation
- Programmable preset for automatic valve positioning
- AUTO open/close feature for quick operation
- Visors in NFPA colors to match pump discharge colors

The Apex-S Visor Color shall be Burgundy.

LOCATION: Left Side

PIPING:

The piping will be stainless steel material throughout the waterway system. The suction waterway shall be 6" 304 stainless steel material. The suction waterways shall be designed to flow a minimum of 17% in excess of the rated capacity from draft. The suction piping shall incorporate a 4" suction inlet to allow for full flow from the tank valve assembly. The suction piping shall be adapted from 6" TIPT to NST with a chrome adapter. The suction system shall be designed with 6" victaulic couplings to allow ease of access for maintenance or removal of the pumping system.

The discharge system shall incorporate a 4" stainless steel distribution system. The manifold shall be fed from the 4" piping system. The discharge system shall incorporate a 4" victaulic system to allow ease of access for maintenance or removal of the pumping system. Each discharge shall be fed from above the manifold system.

PUMP DRAINS:

The entire pump and its controls shall be drainable with a master drain piped to the lowest points of the pump and its control piping. The master drain shall be of a threaded design that will seal all drain points without allowing recycle.

REMOTE PUMP SHIFT:

The PTO driven pump shall be driven from the 10-bolt PTO opening of the automatic transmission through a "Hot-Shift" power take off. The power take off shall be engaged electrically from the cab. Lights shall be positioned at each switch location to indicate PTO engagement.

INTAKE PRESSURE RELIEF VALVE

One (1) Task Force Tips model #A1860 pressure relief valve shall be provided. The valve shall have an easy to read adjustment range from 90 to 300 PSI with easy to read 90, 125, 150, 200, 250, 300 psi settings and an "OFF" position. Pressure adjustment can be made utilizing a ¼" hex key, 9/16" socket or 14mm socket. For corrosion resistance the cast aluminum valve shall be hardcoat anodized with a powder coat interior and exterior finish. The valve shall be configured for either a Waterous or Hale pump, and have a 2-1/2" male NH threaded discharge outlet and a "DO NOT CAP" label near discharge outlet. The valve shall meet NFPA 1901 requirements for pump inlet relief valve. The unit shall be covered by a five-year warranty.

REQUIRED PUMP TESTING:

If the fire pump has a rated capacity of 750 gpm or greater capacity, the pump shall be tested after the

pump and all its associated piping and equipment have been installed on the apparatus. The tests shall be conducted at the Alexis facility and certified by an EVT Certified pump operator. The certification shall include (at least) the following tests: the pumping test, the pumping engine overload test, the pressure control system test, the priming device tests, and the vacuum test. If the apparatus is equipped with a water tank, the water tank to pump flow test shall be included.

A test plate shall be provided at the pump operator's position that gives the following information: the rated discharges and pressures, the speed of the engine determined by the certification test for each unit, the position of the parallel/series pump as used, and the no-load governed speed of the engine stated by the engine manufacturer on a certified brake horsepower curve. The plate shall be completely stamped with all information at the factory and attached to the vehicle prior to shipping.

PUMP CERTIFICATION:

Upon final apparatus delivery, the original copy of the certificate of inspection by an independent third party shall be furnished.

The pumping system shall be capable of delivering:

- 100 % of rated capacity at 150 psi. net pump pressure
- 70 % of rated capacity at 200 psi. net pump pressure
- 50 % of rated capacity at 250 psi. net pump pressure

PUMP MODULE - PTO:

A free standing pump module shall be located between the chassis cab and the body.

The pump module shall be a self-supported structure mounted to the frame separate from the cab and body. Pump module design beginning with a cage framework assemblies that are precision manufactured from corrosion free heavy 7 gauge stainless steel forms. This framework mounts to the truck frame through a mounting design complemented with four (4) VIBRA mount elastomer cushions. The result shall be a mounting system that allows for the twisting movement of the truck frame without undue stress loading of the pump module.

The pump operator's panel shall be located on the left side of the apparatus and the suction/discharge panel shall be located on the right side of the apparatus.

An automotive rubber seal shall be adhered to the pump panel to reduce vibration that may occur during pump operation or road application. The panel shall be attached to the framing with 3/16" pin, 1" knuckle, continuous stainless steel hinges. The hinges shall be attached with stainless steel fasteners.

Each panel shall be secured with latches at the top and bottom of the door opening.

The top left operator's panel shall be hinged for access to the individual gauges and the electrical components. No exceptions.

Once the module is designed, the valve control placements on a control module shall result in a neat and orderly layout. Open the access door on a side control module and peer inside. The horizontal control rods appear neat and orderly.

The top of the pump module shall include a 4-way stainless steel cap.

PUMP OPERATOR'S PANEL:

The pump operator's panel shall include the following:

PRESSURE GOVERNOR and MONITORING DISPLAY

One (1) Fire Research PumpBoss series PBA401-D00 pressure governor and monitoring display kit shall be installed. The kit shall include a control module, intake pressure sensor, discharge pressure sensor, and cables. The control module case shall be waterproof and have dimensions not to exceed 6 3/4" high by 4 5/8". The control knob shall be 2" in diameter with no mechanical stops, have a serrated grip, and a red idle push button in the center. It shall not extend more than 1 3/4" from the front of the control module. Inputs for monitored engine information and outputs for engine control shall be on the J1939 databus. Inputs from the pump discharge and intake pressure sensors shall be electrical.

The following continuous displays shall be provided:

- Engine RPM; shown with four daylight bright LED digits more than 1/2" high
- Check engine and stop engine warning LEDs
- Engine oil pressure; shown on a dual color (green/red) LED bar graph display
- Engine coolant temperature; shown on a dual color (green/red) LED bar graph display
- Transmission Temperature: shown on a dual color (green/red) LED bar graph display
- Battery voltage; shown on a dual color (green/red) LED bar graph display
- Pressure and RPM operating mode LEDs
- Pressure / RPM setting; shown on a dot matrix message display
- Throttle ready LED.

The dot-matrix message display shall show diagnostic and warning messages as they occur. It shall show monitored apparatus information, stored data, and program options when selected by the operator. All LED intensity shall be automatically adjusted for day and night time operation.

The program shall store the accumulated operating hours for the pump and engine to be displayed with the push of a button. It shall monitor inputs and support audible and visual warning alarms for the following conditions:

- High Battery Voltage
- Low Battery Voltage (Engine Off)
- Low Battery Voltage (Engine Running)
- High Transmission Temperature
- Low Engine Oil Pressure
- High Engine Coolant Temperature
- Out of Water (visual alarm only)
- No Engine Response (visual alarm only).

The program features shall be accessed via push buttons located on the front of the control module. There shall be a USB port located at the rear of the control module to upload future firmware enhancements.

The governor shall operate in two control modes, pressure and RPM. No discharge pressure or engine RPM variation shall occur when switching between modes. A throttle ready LED shall light when the interlock signal is recognized. The governor shall start in pressure mode and set the engine RPM to idle. In pressure mode the governor shall automatically regulate the discharge pressure at the level set by the operator. In RPM mode the governor shall maintain the engine RPM at the level set by the operator except in the event of a discharge pressure increase. The governor shall limit a discharge pressure increase in RPM mode to a maximum of 30 psi. Other safety features shall include recognition of no water conditions with an automatic programmed response and a push button to return the engine to idle.

The pressure governor and display shall be programmed to interface with a Cummins engine.

MASTER GAUGES:

One (1) 4½" compound gauge with a range of 30-0-400 PSI.

One (1) 4½" pressure gauge with a range of 0-400 PSI

MAXVISION TANK LEVEL INDICATOR:

Fire Research TankVision model WLA280-A00 tank remote indicator shall be installed. The indicator shall show the volume of water in the tank on Ninety six (96) easy to see super bright Tri-color LEDs. The indicator case shall be waterproof, manufactured of Polycarbonate material with an integrated lens. The package includes a rubber gasket.

The remote indicator shall receive input information over a datalink from a Fire Research TankVision primary indicator model WLA300-A00. The remote indicator shall indicate the level as a single color in Red for 25% or less, Amber color for up to 50% volume, Blue color for up to 75% volume and Green color for up to 100% volume. When the level reaches 25%, the red LEDs will begin flashing. When the level is empty, the red LEDs will scroll in a down-chasing motion and then flash three times. It shall have the program capability to adjust the brightness level for day time and nighttime viewing.

There shall be three (3) MaxVision Tank Level strip lights provided on the apparatus, one (1) each side and one (1) at the rear.

In addition to the LED MaxVision displays, a FRC TankVision WLA300 water level gauge will be located on the pump operator's panel.

Each strip light shall be mounted utilizing a chrome plated flange.

LINE READING GAUGES:

One (1) line reading gauge supplied for each discharge. The gauge shall have a 2½ diameter face with a graduated output scale of 0-400 PSI with black print on a bright white background. The gauge shall be constructed with a Zytel housing, acrylic lens and polished stainless steel bezel. The Zytel nylon case shall be temperature compensated with an internal breathing diaphragm to permit a fully filled case and to allow for a rigid lens with a distortion free viewing area.

A 1/4" brass male NPT fitting shall be centrally located on the rear of the housing and feature the Kem-X socket and freeze protection system that isolates the gauge from contaminants. The gauge utilizes a phosphor bronze Bourdon tube filled with a freeze proof liquid isolated by a diaphragm. The gauge shall be filled with low temperature glycerin for an operating range of -40 to +150 degrees Fahrenheit, which prevents bouncing of the readout needle and provides for an accuracy rating of plus or minus 1% across the entire scale of the gauge.

COLOR CODED TAGS:

Color coded tags with chrome plated bezels shall be provided. Unless otherwise specified all tags shall be color coded to NFPA recommendations and shall be located at the control location, intake/discharge location, and at the drain port location.

Alexis Standard Tags:

Front Bumper Jump Line	Orange
Preconnect #1	Red



Preconnect #2	Yellow
Preconnect #3	Seafoam
Discharge #1	White
Discharge #2	Blue
Discharge #3	Black
Discharge #4	Green
Discharge #5/Water tower	Purple
Deluge/deck gun	Silver
Large-diameter hose	Yellow with white border
Foam line(s)	Red with white border
Booster reel(s)	Gray
Inlets	Burgundy

TEST PORTS:

Vacuum and pressure test ports shall be provided on the pump operator's panel for connection of the pump test gauges.

PUSH BUTTON ON PUMP PANEL FOR AIR HORNS:

There shall be a push button provided on the pump panel to activate the air horns.

RUNNING BOARDS

The running boards shall be constructed of 3/16" thick 3003-H14 aluminum treadplate and shall be attached to the outriggers on the pump module. The aluminum treadplate meets NFPA standard 13-7.3: all exterior surfaces have a minimum slip resistance of .68.

RUB RAILS - RUNNING BOARDS:

Bolt on aluminum rub rails shall be installed one (1) each side on the running boards. Said rub rails will be fabricated of a polished "C" channel aluminum, mounted to the running board utilizing 1/4" plastic spacers.

The rub rails shall incorporate the LED ground lights. Each light strip shall run the full length of each rub rail.

The channel designed rub rail shall incorporate a highly reflective red and fluorescent yellow green reflective stripe to aid in apparatus protection.

STAINLESS STEEL PUMP MODULE:

The area above the side discharge panels on each side shall be manufactured of 14 gauge brushed stainless steel material.

STAINLESS STEEL PUMP PANELS:

The pump operator's panel and discharge panels shall be manufactured of 12-gauge stainless steel and shall include a full width light hood with one (1) E45 Series LED light strip

The side discharge panel on the passenger side of the apparatus shall be manufactured of 12-gauge stainless steel and shall include a full width light hood with one (1) E45 Series LED light strip

The lights shall be activated by a switch located on the pump operator's panel.

PUMP MODULE TOP:

MATTYDALE PRECONNECTS:

Three (3) Mattydale preconnects shall be located across the top of the apparatus body. Two (2) of the preconnects shall measure 1½", and one (1) of the preconnects shall measure 2½".

The 1½" preconnects shall incorporate a 1½" 180° swivel adapted to 1½" fire hose thread. The water ways shall be 2" i.d. and shall include a 2" full flow quarter turn ball valve that is remote controlled from the operator's panel.

The 2½" preconnect shall incorporate a 2½" swivel adapted to 2½" fire hose thread. The water way shall measure 3" i.d. and include a 2½" full flow quarter turn ball valve that is remote controlled from the operator's panel.

The 1½" preconnects shall have the capacity to contain a minimum of 200 ft. of 1¾" hose, and the 2½" preconnect shall have the capacity to contain a minimum of 150 ft. of 2½" hose. The Mattydale preconnects shall be designed to allow the extension of hose to the right or left side of the apparatus body. The preconnect openings shall incorporate aluminum abrasion plates to protect the body finish from the hose and its couplings during extension or relay.

Each above valve shall be manually controlled.

PRECONNECT HOSE RETENTION - STRAP:

The preconnect area shall include 2" nylon straps for hose retention. Each strap shall include a seat belt buckle for ease of access. There shall be one (1) strap at each end and one (1) strap on each side across the top, total of four (4) straps.

2 ½" DISCHARGE PIPING:

One (1) 2 ½" discharge(s) shall be located on the left side of the apparatus. Each discharge valve shall be located behind the body panel and controlled from the side control pump operator's panel. Each discharge shall include a self-locking 2½" quarter-turn ball valve, a 2½" chrome cap with chain, and a sweep elbow of at least 30 degrees downward.

Each above valve shall be manually controlled.

2 ½" DISCHARGE PIPING:

One (1) 2 ½" discharge(s) shall be located on the right side of the apparatus. Each discharge valve shall be located behind the body panel and shall be controlled from the side control pump operator's panel. Each shall include a self-locking 2½" quarter-turn ball valve, a 2½" chrome cap with chain, and a sweep elbow of at least 30 degrees downward.

Each above valve shall be manually controlled.

2 ½" DISCHARGE, APPARATUS REAR:

One (1) 2½" discharge shall be located on the rear of the apparatus. Each discharge shall be controlled from the side control pump operator's panel. Each shall include a self-locking 2½" quarter-turn ball valve, a 2½" chrome cap with chain, and a sweep elbow of at least 30 degrees downward.

Each above valve shall be manually controlled.

LOCATION: _____

3" DISCHARGE(S), APPARATUS RIGHT SIDE:

One (1) 3" discharge(s) shall be located on the right side of the apparatus with each valve behind the body panel. Each discharge shall be controlled from the side control pump operator's panel. A 2½" gauge shall be adjacent to each control. Each valve shall measure 3" and include an Akron Slo-Cloz adapter.

DISCHARGE ADAPTER:

The 3" discharge shall incorporate one (1) 3" NST LHF x 5" Storz 30 degree elbow with blind cap.

Each above valve shall be manually controlled.

TANK TO PUMP LINE:

One (1) 3" tank to pump line shall be installed into the tank to the suction side of the pump. It shall have 4" piping and valved with a 3" full flow valve. The valve shall be controlled from the pump operator's panel. The tank line shall incorporate a check valve in the line to meet NFPA 1901.

LINE DRAINS FOR DISCHARGES:

The drain valves shall be Innovative Controls ¾" ball brass drain valves with chrome-plated lift lever handles and ergonomic grips. Each lift handle grip shall feature built-in color-coding labels and a verbiage tag identifying each valve, also supplied by Innovative Controls. The color labels shall also include valve open and close verbiage.

VENTED DISCHARGE CAPS:

Each discharge shall incorporate a vented cap designed to relieve stored pressure in the line when disconnected.

GATED SUCTION, LEFT SIDE:

One (1) 2½" gated suction shall be located on the left side of the apparatus. It shall be piped 2½" i.d. including a 2½" Akron full flow quarter turn valve and a 2½" NST female swivel with plug and chain. It shall be remote controlled from the suction location.

Each above valve shall be manually controlled.

FRONT SUCTION:

One (1) 4" suction shall be located at the front of the apparatus. **It is to be piped with 4" SS piping and shall terminate through the front face of the bumper on the right side** as described below. The operator shall have an open-closed indicator device showing the valve position at all times. The butterfly valve shall be made of lightweight aluminum alloy with a bronze valve disc and a one (1) piece rubber seat. It shall be rated at 250 psi. working pressure. The electric actuator shall have a worm gear drive system with emergency manual override. All of the controls shall be within a single mountable panel package that utilizes current limiting for fully open and closed stopping. Switches in the gear

actuator housing will not be acceptable.

THE FRONT SUCTION SHALL BE CONTROLLED AND VALVED WITH AN ELKHART 4" VALVE AND APEX -S CONTROLLER LOCATED ON THE PUMP PANEL

INTAKE RELIEF VALVE:

One (1) TFT A1860 intake relief valve shall be installed on the auxiliary intake of the pump. The minimum range shall permit control from 75 to 250 psi. (per NFPA 4-5.1).

One (1) 4" NPTF x 6" NSTM with screen, chrome plated.

FIXED MONITOR PIPING:

One (1) 3" discharge shall be located on the deck over the pump compartment. The discharge shall be flanged to adapt to a permanent mounted deck pipe. The piping shall be reinforced to allow rated deck pipe flow without piping distortion. The discharge valve shall be a quarter turn 3" full flow valve located in the pump compartment. It shall be controlled from the pump panel. The deluge and its control shall be positioned so the pump operator shall have complete control. The valve shall be a slow close valve per NFPA requirements.

Each above valve shall be manually controlled.

TANK FILL RECYCLE:

One (1) 2" waterway shall be incorporated from the pressure side of the pump to the tank. The line shall be controlled from the pump panel and valved with a 2" ball valve to allow a pump cooling recycle or tank fill when pumping from draft. When fully opened, it shall have the capacity to refill the tank at 750 gpm when pumping at 100 psi.

VALVING:

Each and every apparatus valve must be an Akron Stainless Steel Ball Valve, per the following specifications.

An Akron Brass Generation II Swing-Out™ Valve, shall be provided. The valve shall have an all brass body with flow optimizing stainless steel ball and dual polymer seats. The valve body shall be of universal design and accept multiple actuators. The valve shall be capable of dual directional flow while incorporating a self-locking ball feature using an automatic friction lock design and specially designed flow optimizing stainless steel ball. The stainless steel ball shall have HydroMax™



technology. All stainless steel parts must be 316 grade for increased resistance to corrosion. The valve shall not require lubrication of seats or any other internal waterway parts, and must be capable of swinging out of the waterway for maintenance by the removal of six bolts. The valve shall be compatible with a slow closing device. This valve shall be actuated using a manual handle. The handle shall be quickly adjustable to one of eight handle positions and require only 90° travel. The valve shall be manufactured and assembled in the United States. Product must carry a 10 year manufacturer's warranty.

WARRANTY, AKRON BRASS BALL VALVE:

We warrant Akron Brass Swing-Out Valves for a period of ten (10) years after purchase against defects in material or workmanship. Akron Brass will repair or replace any Swing-Out Valve which fails to satisfy this warranty. Repair or replacement shall be at the discretion of Akron Brass. Electrical Components shall carry our standard five (5) year warranty. We will not be responsible for: Wear and tear; and by improper installation use, maintenance; negligence of the owner or user; repair or modification after delivery; failure to follow our instructions or recommendations; or anything else beyond our control. WE MAKE NO WARRANTIES EXPRESS OR IMPLIED, OTHER THAN THOSE INCLUDED IN THIS WARRANTY STATEMENT, AND WE DISCLAIM ANY IMPLIED WARRANTY OF MERCHANTABILITY OR FITNESS FOR ANY PARTICULAR PURPOSE. Further we will not be responsible for any consequential, incidental, or indirect damages (including, but not limited to, any loss of profits) from any cause whatsoever. No person has authority to change this warranty.

PIPING:

All waterways described herein shall be of schedule 40 threaded stainless steel pipe, schedule 10 welded stainless steel, or "aeroquip" hose. Each shall be installed with the proper couplings to allow apparatus twisting, flexing, and complete removal for service or replacement.

PLUMBING WARRANTY:

The stainless steel plumbing components and ancillary brass fittings used in the construction of the water/foam plumbing system shall be warranted for a period of ten (10) years or 100,000 miles. This covers structural failures caused by defective design or workmanship, or perforation caused by corrosion, provided the apparatus is used in a normal and reasonable manner. This warranty is extended only to the original purchaser for a period of ten (10) years or 100,000 miles from the date of delivery.

PIPING CERTIFICATION:

Upon final apparatus delivery, a certification sheet shall accompany the unit stating that all piping and



the pump have been hydrostatically tested to 250 psi.

BODY:

BODY WARRANTY:

Alexis Fire Equipment Company hereby extends its standard one-year fire and rescue apparatus warranty to include defects in materials and workmanship of the body as well as structural defects which, in the sole opinion of the company, substantially affect the total integrity of the body. This warranty is extended only to the original user-purchaser.

Alexis Fire Equipment warrants the 3/16" aluminum bodies, under normal use and with reasonable maintenance, shall remain structurally sound for a period of 10 years or 100, 000 miles as long as the design of the apparatus complies with Alexis engineering practices.

The Company reserves the right to require any such repairs to be made either at Alexis Fire Equipment Company, Inc. or another approved service facility, at the option of Alexis Fire Equipment. Transportation cost to and from the servicing location is the responsibility of the user-purchaser.

The warranty shall be null and void if, upon inspection by the Company, the alleged defect is determined to have been caused by abuse, modification, accident, neglect, or lack of proper maintenance.

This warranty does not apply to the following items that are covered by a separate warranty: paint finish, hardware, door assemblies, moldings, and other accessories attached to the body. In addition, this warranty does not apply to any part or accessory manufactured by others and attached to the body.

Alexis Fire Equipment will be given a reasonable opportunity to investigate all claims. The purchaser must commence any action arising out of, based upon or relating to agreement or the breach hereof, within twelve (12) months from the date the cause of the action occurred.

Alexis Fire Equipment makes no other warranty, expressed or implied, with respect to the apparatus body and all implied warranties of merchantability and fitness for a particular purpose are hereby disclaimed.

ASHLAND SERIES BODY:

BODY SUB FRAME:

The body subframe system shall be independent of the chassis frame and is to be constructed of

aluminum structural material. The subframe shall be mounted in a manner that allows the body to float independent of the chassis frame. However, the unit will be secured in compliance with all chassis manufacturers' frame requirements, as well as with all SAE FMVSS standard requirements. The chassis frame shall be completely cushioned from the subframe system with closed cell rubber.

APPARATUS FRONT PANEL:

The vertical surfaces at the front of body shall be manufactured of .190" aluminum treadplate.

INDEPENDENT ALUMINUM BODY PANELS:

The apparatus body panels shall be full height and independent of the tank's sides. The body panels shall be constructed of .190 thick 5052 aluminum material. The material shall be broke 2" over on all edges for added strength. The panels shall be painted to match the lower body.

APPARATUS REAR PANEL:

The vertical surfaces between the body rails at the rear, from the tailstep walkway to the top of the body, shall be manufactured of smooth aluminum in preparation for Chevron striping.

WHEEL HOUSING, PAINTED SMOOTH ALUMINUM:

The rear wheel housing shall be constructed of painted smooth aluminum and shall incorporate a stainless steel fenderette. The circular interliner shall be manufactured of 1/8" smooth aluminum

HOSE MAT:

The hose mat shall be constructed of 5052 aluminum and shall be of a slatted design to provide proper drainage of hose bed.

TAILSTEP:

The tailstep shall be constructed of .190 thick 3003-h14 aluminum treadplate. The tailstep shall be a bolt-on tailstep for ease of removal and repair. The aluminum treadplate meets NFPA standard 13-7.3: all exterior surfaces have a minimum slip resistance of .68.

The tail step shall incorporate 45° tapered corners.

The tail step shall be 24" deep

REAR TOW EYES:

Two (2) ¾" thick steel tow eyes shall be securely fastened to the rear frame rails, one (1) on each side below the body.

HOSE BED:

The hose bed shall be located over the booster tank, and must be accessible from the tail step and from its open top. The hose bed compartment shall have a minimum capacity of 55 cu. ft. and a minimum width of 71".

HOSE BED CAPACITY:

The hose bed shall have the capacity to carry the following hose from left to right:

Ten (10) 100' sections of 4" LDH Hose

No Hose Lay 4

HOSE BED DIVIDER:

One (1) divider shall be located in the hose bed. It shall be constructed of 3/16" aluminum plate. The divider shall be designed for future adjustability with locking blocks in aluminum channels at the front and the rear of the hose bed.

Each hose bed divider shall incorporate hand hold cutouts to assist in accessing the hose bed.

HOSE BED COVER:

One (1) custom tailored hypalon hose bed cover shall be included with the apparatus body. It shall be manufactured of a flame retardant material with a grab tensile of 480 x 500 lbs. and a tongue tear of 160 x 150 lbs. It shall be crack resistant to -40° Fahrenheit and have an adhesion lbs./in of 10.0 lbs. The hose bed cover shall be fitted to the hose bed and retained with a double woven shock cord on the front and both sides. The shock cord shall system shall utilize nylon hooks spaced every 10"-12". The cover shall be sand weighted across the rear flap and shall also include two (2) 2" wide nylon straps with teflon buckle to meet NFPA requirements.

The hose bed cover shall include a 3 year warranty.

The hypalon cover shall be red in color.

COMPARTMENTATION:

COMPARTMENT DESIGN:

The compartmentation shall be fabricated of 3/16" (.1875") thick 5052 H32 aluminum. The compartmentation is designed to be an intricate part of the body and subframe for maximum compartment support. The compartment tops shall be fabricated of aluminum treadplate material. The material shall be formed over each compartment top to act as drip protection over each compartment opening. The compartment flooring will be sweep out design. The front face of the compartments shall be aluminum treadplate and the rear face the compartments shall be smooth aluminum in preparation for Chevron striping.

The specified lighting in each compartment shall be switched automatically with the doors. The lighting shall meet the requirements of NFPA 13.10.5

NON-PAINTED ROLL-UP DOORS:

The compartments shall have ROM Series IV Roll-up Shutter Doors with a satin finish. The doors shall be made of an anodized aluminum slat incorporating an exclusive seal that prohibits water intrusion, absorbs shock, eliminates clatter, and provides quiet, vibration-free performance. The lift bar shall be a D-shaped bar for strength and ease of use.

TALL BOTTOM RAIL:

Each ROM door shall incorporate a tall bottom rail for improved accessibility.

LEFT SIDE BODY SHALL BE AS FOLLOWS:

L1

A roll-up door compartment assembly with a door opening of 61" wide x 31" high x 25" deep shall be incorporated on the apparatus left side ahead of the rear wheels.

The compartment shall include the following:

Unistrut Tracking

E45 Series LED strip lights to illuminate the entire area. The lights shall run the entire height of the compartment on each side of the door opening.



L2

A roll-up door compartment assembly with a door opening of 27" wide x 31" high x 25" deep shall be incorporated on the apparatus left side behind the rear wheels.

The compartment shall include the following:

Unistrut Tracking

E45 Series LED strip lights to illuminate the entire area. The lights shall run the entire height of the compartment on each side of the door opening.

RIGHT SIDE BODY SHALL BE AS FOLLOWS:

R1

A roll-up door compartment assembly with a door opening of 61" wide x 31" high x 25" deep shall be incorporated on the apparatus right side ahead of the rear wheels.

The compartment shall include the following:

Unistrut Tracking

E45 Series LED strip lights to illuminate the entire area. The lights shall run the entire height of the compartment on each side of the door opening.

R2

A roll-up door compartment assembly with a door opening of 27" wide x 31" high x 25" deep shall be incorporated on the apparatus right side behind the rear wheels.

The compartment shall include the following:

Unistrut Tracking

E45 Series LED strip lights to illuminate the entire area. The lights shall run the entire height of the compartment on each side of the door opening.

FOLDING TANK BRACKET- HORIZONTAL SLIDE IN:

One (1) compartment for a folding tank shall be installed vertically on the right side of the tank. The compartment shall be integral to the water tank and constructed of poly material. The compartment shall incorporate a treadplate door with single point latch.

Each bracket shall have the capacity for a 2100 gallon fol-da-tank.

SUCTION HOSE STORAGE:

Two (2) suction gutter for a 10 ft. length of suction hose shall be installed on the exterior of the apparatus in the specified location. Each gutter shall be manufactured of 5052-H32 aluminum sheet and supported on aluminum brackets.

Each length of suction hose shall be retained with looped polyester straps and polyester Velcro #2000 loop, #80 hook. The retaining assembly shall be water proof, humidity proof and impervious to ultraviolet.

Each suction gutter shall remain natural finish aluminum.

LOCATION: Left Side

LADDER BRACKETS:

One (1) set of Cast Products FA0030-5 ladder brackets with chrome-plated retainers shall be installed on the apparatus. A retainer shall be included to hold the extension ladder in place with the roof ladder removed.

ATTIC LADDER BRACKET:

One (1) attic ladder bracket shall be provided. It shall have the capacity to carry an attic ladder. Abrasion pads shall be installed to prevent body finish damage.

The ladder storage shall have the capacity to contain the following:

One (1) 24' 2-Section Ladder

One (1) 14' Roof Ladder with Hooks

One (1) 10' Attic Ladder

LOCATION: Right Side

RUB RAILS:

Bolt on aluminum rub rails shall be installed, below the compartment doors. Said rub rails will be fabricated of a polished "C" channel aluminum, mounted to the body surface utilizing ¼" plastic spacers. The channel designed rub rail shall incorporate a highly reflective red and fluorescent yellow green reflective stripe to aid in apparatus protection.

The rub rails shall incorporate the LED ground lights and LED lower warning lights. Each light strip shall run the full length of each rub rail.

DURATILE TILE ON FLOOR:

The floor of each main body compartment shall be covered with black Duratile Tile.

TANK:

BOOSTER TANK:

The tank shall have a capacity of 2000 US gallons complete with a lifetime warranty. The tank manufacturer shall mark the tank and furnish notice that indicates proof of warranty. The purpose of the markings and notice is to inform department personnel who store, stock, or use the tank that the unit is under warranty. Markings may be brief but should include a short statement that a warranty exists, the substance of the warranty, its duration, and who to notify if the tank is found to be defective.

The tank shall be constructed of ½" thick PT2E polypropylene sheet stock. This material shall be non-corrosive stress relieved thermo-plastic and U.V. stabilized for maximum protection.

The booster tank shall be of a specific configuration and so designed to be completely independent of the body and compartments. All joints and seams shall be nitrogen welded and tested for maximum strength and integrity. The transverse swash partitions shall be manufactured of 3/8" PT2E polypropylene (natural in color) and extend from approximately 4" off the floor to just under the cover. The longitudinal swash partitions shall be constructed of 3/8" PT2E polypropylene (natural in color) and extend from the floor of the tank through the cover to allow for positive welding and maximum integrity. All partitions shall be equipped with vent and air holes to permit movement of air and water between compartments. The partitions shall be designed to provide maximum water flow. All swash partitions interlock with one another and are welded to each other as well as to the walls of the tank.

FILL TOWER AND COVER

The tank will have a combination vent and manual fill tower. The fill tower will be constructed of ½" PT2E polypropylene and shall be a minimum dimension of 8" x 8" outer perimeter. The tower will be located in the left front corner of the tank. The tower will have a ¼" thick removable polypropylene screen and a PT2E polypropylene hinged type cover. Inside the fill tower, approximately 4" down from the top, shall be fastened a combination vent overflow pipe. The vent overflow shall be a minimum of schedule 40 polypropylene pipe with a minimum I.D. of 4" that is designed to run through the tank and shall be piped behind the rear wheels.

The tank cover is constructed of ½" thick PT2E polypropylene and UV stabilized, to incorporate a multi three-piece design which allows for individual removal and inspection if necessary. The tank cover will be recessed 3/8" from the top of the tank and shall be welded to both sides and longitudinal partitions for maximum integrity. Each one of the three covers will have hold-downs consisting of 2" polypropylene dowels spaced a maximum of 30" apart. These dowels will extend through the covers and be welded to the transverse partitions. This will assist in keeping the cover rigid under fast filling conditions. A minimum of two (2) lifting dowels shall be drilled and tapped ½" x 13" to accommodate the lifting eyes.

SUMP

There will be one (1) sump standard per tank. The sump shall be constructed of ½" PT2E polypropylene and be located in the left front quarter of the tank. The sump will have a minimum 3" NPT threaded outlet on the bottom for a drain plug. This shall be used as a combination cleanout and drain. All tanks shall have an anti-swirl plate located approximately 2" above the sump.

OUTLETS

There will be two (2) standard tank outlets: one for the tank to pump suction line which will be a minimum of a 3" NPT coupling and one for a tank fill line which will be a minimum of a 2" NPT coupling. All tank fill couplings will be backed with flow deflectors to break up the stream of water entering the tank, and be capable of withstanding sustained fill rates of up to 1000 GPM. All auxiliary outlets and inlets must meet all NFPA guidelines in effect at the time of manufacture.

MOUNTING

The tank shall rest on the body cross members with an unsupported area not to exceed 530 sq. inches on tanks up to 40" in height. On tanks over 40" in height, an unsupported area of not more than 400 sq. inches must be maintained. All tanks shall be isolated from the cross members through the use of hard rubber strips with, a minimum thickness and width dimension of .250 x 2" and a minimum Rockwell hardness of 60 durometer. Additionally, the tank must be supported around the entire bottom outside

perimeter and captured both front and rear as well as side to side to prevent the tank from shifting during vehicle operation. A picture frame type cradle mount shall be utilized with a minimum of 2" x 2" x .250 structural material.

Although the tank is designed on the free-floating suspension principle, it shall be required that the tank have hold down restraints half way between the front and the rear of the tank. These restraints shall be made of 3" x 3" x ¼" angle approximately 6" long. The restraints shall be mounted to the side walls of the hose bed and extend down so that they rest approximately ½" above the top of the tank. The tank shall be completely removable without disturbing or dismantling the apparatus structure.

Upon final apparatus delivery, proper evidence and certifications shall be presented indicating the tank has the capacity of flow to the pump 80% of its rated capacity at a flow rate of 2000 GPM.

TANK FILL - 2½":

One (1) 2½" NH tank fill connection shall be located at the rear of the apparatus. The assembly shall include a FirePrograms 4" Stainless Steel Fill Valve, Model 5001751, four-inch inside diameter internal check valve with appropriately sized hose connection. The assembly shall also include a ¾" quarter turn line drain.

The FirePrograms 4" Fill Valve is an internally mounted check-type fill valve, capable of flowing at a rate up to 1,000 GPM. The Fill Valve is available in a 4" Victaulic connection or 4" male NPT pipe thread connection for ease of installation. The Fill Valve is self-deflecting, requiring no additional diffusion device. The Fill Valve is constructed of 100% stainless steel avoiding the use of dissimilar metals. The spring actuated piston-type sealing mechanism minimizes seal wear and provides positive sealing of the valve after shutting off the valve at the feed source. The device is designed to be self-cleaning utilizing a replaceable EPDM rubber gasket. Less than 6psi is required to open the valve.

Utilizing two stainless steel internal tank mounting plates, the 4-bolt Fill Valve mechanism is attached directly through the tank wall. The valve design is suitable for simple retrofit installation into existing water tanks.

LOCATION: _____

TANK DUMP:

One (1) 10" x 10" square Newton stainless steel swivel dump Model 6012SW-34 with a flip up gate valve shall be installed. It shall include an over center safety lock. The valve shall be bolted to the tank with stainless steel bolts.



The dump shall incorporate a swivel allowing 180° rotation from left to right.

The dump shall be manually controlled from the dump location.

DUMP EXTENSION:

One (1) Newton 36" manually controlled stainless steel extension, model 4036-34, shall be installed on each dump.

The dump shall be located at the rear of the apparatus.

12 VOLT ELECTRICAL:

12 VOLT ELECTRICAL SYSTEM:

Our electrical system is engineered to provide many years of dependable, trouble free service.

The 12 volt apparatus wiring shall be completely independent of the chassis electrical system. The system shall incorporate a state-of-the-art electrical distribution center. The center shall include a microprocessor, automatic reset circuit breakers, and switching relays.

12 VOLT DISTRIBUTION CENTER:

The 12 Volt distribution center shall be located in the L1 compartment on the front wall, behind an access panel. The access panel shall incorporate a laminated wiring diagram for ease of maintenance of the electrical system.

A 12 volt fan shall be provided in the distribution center to enhance the air flow around the electrical equipment. The fan shall be switched with the master switch.

ELECTRICAL SYSTEM PERFORMANCE TESTS:

The apparatus low voltage electrical system shall be tested and certified per the current NFPA standard. The certification shall be delivered to the purchaser with the apparatus.

DOCUMENTATION:

At the time of delivery, the manufacturer shall provide the following:

- (a) Documentation of the electrical system performance tests;

(b) A written load analysis, including:

1. The nameplate rating of the alternator;
2. The alternator rating;
3. Each component load comprising the minimum continuous load;
4. Additional loads that, when added to the minimum continuous load, determine the total connected load;
5. Each individual intermittent load.

ON BOARD BATTERY CHARGER:

One (1) Progressive Dynamics PD2140 battery charger shall be installed on the vehicle. The unit shall be located in the L1 compartment.

The PD2140 is a 40-amp Electronic Marine Converter/Charger capable of charging up to three separate banks of batteries at the same time. It incorporates a microprocessor that constantly monitors battery voltage, then automatically selects one of four operating modes to ensure safe, rapid recharging cycles. The Storage Mode and the Equalize Mode of operation ensures minimum battery gassing and water loss while preventing battery stratification and sulfation. All Intelli-Power chargers are designed to meet the stringent requirements of the Marine environment and are UL listed for safety. A digital meter displays current, voltage, operation mode, blown fuse indication, and battery type.

REMOTE DISPLAY:

A Blue Sea 1733 Mini digital display shall be supplied and installed adjacent to the shoreline connection. The display monitors DC voltage on a bright, waterproof, daylight readable OLED screen.

KUSSMAUL SUPER AUTO EJECT SHORELINE CONNECTION - 120V:

One (1) Kussmaul super auto eject Model 091-55-20-120 with a standard yellow weather cover shall be installed on the apparatus. The super auto eject is a completely sealed automatic power line disconnect. One (1) 120-Volt shoreline shall be supplied between the fire station power and the apparatus.

The shoreline connection shall be located in the left rear wheel well area, ahead of the wheels.

MASTER SWITCH:

A 12 Volt Cole-Hersee Rotary switch shall be installed on the side of the floor mounted console. When in the OFF position, the master switch system shall isolate all electrical power from the apparatus. It shall not interrupt any primary battery/starter wiring originally furnished by the chassis manufacturer.

FLOOR MOUNTED CONSOLE FOR EMERGENCY SWITCHES:

One (1) 12 volt floor mounted console shall be installed in the apparatus. The console shall be manufactured of black textured composite material. The console shall incorporate the switch row and two (2) slots, one (1) for the electronic siren and one (1) slot for the radio.

RADIO PROVISIONS:

One (1) customer supplied single head radio provision shall be provided in the chassis cab. The cutout shall accommodate the radio make and model specified and shall include a bezel specific to the radio specified.

RADIO WIRING:

Radio wiring shall be provided for the customer supplied and installed radio. The wiring shall include power and ground leads, battery direct and master switched.

ANTENNA:

One (1) Alexis Fire Equipment supplied antenna base, for use with an NMO type antenna, shall be mounted on the cab roof. The antenna base shall be a Motorola base designed for either thick or thin roof material as appropriate for the application and shall include a custom length of RG58 A/U cable with no connector at the radio end of the cable. The cable shall terminate at the center console area.

The radio make and model shall be: _____

TIRE PRESSURE MONITORING DEVICE:

One (1) set of Real Wheels LED Air Guard tire pressure indicators shall be shipped loose with the completed apparatus. Features and benefits of the LED Air Guards include

- Safety – Improper tire pressure has a detrimental effect on handling, braking and control.
- Longer Tire Life – According to the D.O.T., 95% of all premature tire wear is caused by underinflation.
- Self-calibrating – LED AirGuard Set & Go memorizes pressure when initially installed and can be easily recalibrated by simply removing and reinstalling.
- Improved Fuel Economy – Proper tire inflation can save an estimated 3% to 5% in fuel costs.

OPTICAL WARNING SYSTEM:

The optical warning system on the fire apparatus shall be capable of two separate signaling modes during emergency operations. One mode shall signal to drivers and pedestrians that the apparatus is responding to an emergency and is calling for the right-of-way. The other mode shall signal that the apparatus is stopped and is blocking the right-of-way.

EMERGENCY WARNING LIGHTS:

For the purpose of defining and measuring the required optical performance, the apparatus shall be divided into four warning zones. The four zones shall be determined by drawing lines through the geometric center of the apparatus at 45° to a line lengthwise of the apparatus through the geometric center. The four zones shall be designated A, B, C, and D in a clockwise direction with zone A to the front of the apparatus. Each zone shall have an upper and lower warning level.

Effective coverage of all four zones, both upper and lower, as required by the latest NFPA Edition shall be provided.

LED LIGHTBAR:

One (1) Whelen Model F4N2VLED 55" LED lightbar shall be mounted on the cab roof. The lightbar shall be switched from the in cab switch panel. This lightbar fills the requirements of Zone A Upper, Zone B Upper, and Zone D Upper.

The light bar shall feature four (4) corner red LED modules, two (2) forward facing red LED modules, and two (2) forward facing clear LED Modules.

The clear modules shall extinguish when blocking the right of way per NFPA. A stinger switch shall also be provided for control of the white lights in inclement weather.

WARNING LIGHTS (FRONT):

Two (2) Tecniq Model K60-R*00-1 Red LED warning lights shall be mounted on the front cab face, one (1) on each side. These lights shall be switched from the in cab switch panel. These lights fill the requirements of Zone A Lower.

Each light shall be mounted utilizing a chrome plated flange.

Each light shall incorporate a colored lens.

WARNING LIGHTS (SIDE):

One (1) Tecniq Model K60-R*00-1 Red LED warning light shall be mounted on the right (officer's) side of the cab. The light shall be switched from the in cab switch panel. The light fills the requirements of Zone B Lower.

One (1) Tecniq Model K60-R*00-1 Red LED warning light shall be mounted on the left (driver's) side of the cab. The light shall be switched from the in cab switch panel. The light fills the requirements of Zone D Lower.

The rub rails on each side of the body shall incorporate integral outward facing Red LED strip lights. In addition to the Red LED strip light, the rub rail on each side ahead of the rear wheels shall incorporate one (1) TecNiq E03-D001-1 LED light. These lights shall be switched from the in cab switch panel.

In addition to the Tecniq Red Eon LED light in the rub rail ahead of the rear wheels on each side, one (1) additional Tecniq Red Eon LED light shall be provided in the rub rail behind the rear wheels on each side. These lights shall be switched from the in cab switch panel.

Each cab side light shall be mounted utilizing a chrome plated flange.

Each light shall incorporate a colored lens.

WARNING LIGHTS (SIDE):

One (1) Tecniq Model K90-R*00-1 Red LED warning light shall be mounted on the right (officer's) side of the vehicle in the upper area. The light shall be switched from the in cab switch panel.

One (1) Tecniq Model K90-R*00-1 Red LED warning light shall be mounted on the left (driver's) side of the vehicle in the upper area. The light shall be switched from the in cab switch panel.

These lights fill the requirements of Zones B & D Upper.

Each light shall be mounted utilizing a chrome plated flange.

Each light shall incorporate a colored lens.

WARNING LIGHTS (REAR UPPER):

Two (2) Tecniq Model K90-R*00-1 Red LED lights shall be mounted on the rear of the vehicle, in the upper area. The lights shall be switched from the in cab switch panel. These lights fill the requirements

of Zone C Upper.

Each light shall be mounted utilizing a chrome plated flange.

Each light shall incorporate a colored lens.

WARNING LIGHTS (REAR):

Two (2) Tecniq Model K60-R*00-1 Red LED warning lights shall be mounted on the lower rear area of the vehicle. These lights shall be switched from the in cab switch panel. These lights fill the requirements of Zone C Lower.

Each light shall be mounted utilizing a chrome plated flange.

Each light shall incorporate a colored lens.

REAR DRIVING SIGNALS:

The rear driving signals shall consist of two (2) Code 3 7X9STTRBZ LED lights, one (1) each side of the apparatus at the rear. The 7X9 LED lights shall incorporate red brake/tail, amber turn, and white backup in a single light head. The mounting shall include a chrome bezel.

ELECTRONIC SIREN:

One (1) Whelen Model 295SLSA1 siren shall be installed in the apparatus. The siren shall be mounted in the cab and shall include a noise-canceling microphone.

SIREN SPEAKER:

One (1) Whelen Model SA315 100 watt siren speaker shall be installed in the apparatus bumper.

TURN SIGNALS-MIDSHIP:

One (1) S34 Series amber LED midship turn light shall be mounted on each side of the apparatus ahead of the rear wheels.

ICC LIGHTING:

S34 Series LED Clearance lights shall be installed on the apparatus. They shall be hermetically sealed cartridge lights for ease of service and durability.

LED REAR LICENSE PLATE BRACKET:

There shall be a Cast Products LED license plate bracket provided at the rear of the apparatus.

HAZARD LIGHT:

A red, LED flashing light located in the driving compartment shall be illuminated automatically whenever the apparatus parking brake is not fully engaged and any passenger or equipment compartment door is open, any ladder or equipment rack is not in the stowed position, a stabilizer system is deployed, a powered light tower is extended, or any other device is opened, extended, or deployed that creates a hazard or is likely to cause damage to the apparatus if the apparatus is moved. The light shall be marked "Do Not Move Apparatus When Light Is On".

LED COURTESY LIGHTS (UNDER CARRIAGE LIGHTING):

One (1) 5" 12-volt T44 Series LED light shall be located under each cab door and one (1) shall be located below the rear tail step in the center. All ground area lighting shall be controlled by the master switch and shall be switched with the parking brake.

In addition to the 5" lights, clear LED strip lights shall be provided integral to the rub rails on each side. The strip lights shall face downward and be activated with the balance of the undercarriage lighting.

LED TAILBOARD COURTESY LIGHTS:

Two (2) S34 Series LED courtesy lights shall be mounted one (1) each side low on the rear panel. The lights shall illuminate the rear tailboard. They shall be switched with the parking brake.

LED RUNNING BOARD COURTESY LIGHTS:

One (1) S34 Series LED courtesy light shall be mounted on each side low on the front of the body. Each light shall illuminate the running board area. The lights shall be switched with the parking brake.

FIRETECH 12-VOLT LED SCENE LIGHT(S):

Two (2) FireTech FT-MB-2.36-FT-* 40" Double Stack 38,016 lumen LED bar scene light(s) shall be mounted in the specified location(s). The lights shall be switched from the in-cab switching station.

Each Firetech Hi Viz scene light bar shall be surface mounted in the specified location.



Each Firetech Hi-Viz scene light shall be white in color.

SIDE SCENE LIGHT LOCATION(S): One (1) Each Side

SCENE LIGHTS:

Two (2) LED scene light(s), Whelen Model 9SC0ENZR with 6500 lumen output, shall be mounted in the specified location(s). Each scene light shall be switched from the cab console.

Each light shall be mounted utilizing a chrome plated flange.

SIDE SCENE LIGHT LOCATION(S): One (1) Each Side

HOSEBED STRIP LIGHTING - LED:

Two (2) E45 Series LED Strip lights shall be provided at the front of the apparatus hose bed. The lights shall be switched with the parking brake.

BRACKETING:

FOLDING STEPS:

Six (6) large folding steps shall be furnished on the apparatus.

Location: Rear tail step area.

Each folding step shall have a chrome finish

GRAB HANDLES:

Two (2) 1¼" o.d. 12" knurled bright stainless steel grab handle(s) shall be provided.

Each grab handle shall have a natural stainless steel finish

LOCATION: UPPER REAR BODY RAIL

GRAB HANDLES:

Two (2) 24" knurled bright stainless steel 1¼" O.D. grab rails shall be installed vertically on the rear of the body.



Each grab handle shall have a natural stainless steel finish

GRAB HANDLE:

One (1) 48" knurled bright stainless steel 1¼" O.D. grab rail shall be installed horizontally below the apparatus hose bed.

Each grab handle shall have a natural stainless steel finish

GRAB HANDLE:

One (1) 36" knurled bright stainless steel 1¼" O.D. grab rail shall be installed horizontally below the apparatus hose bed.

FINISH:

APPARATUS BODY FINISH:

The final finish of the apparatus shall conform to fire apparatus standards, exhibiting excellent gloss durability and color retention properties.

PREPARATION:

Since the removal of all contaminants and oxidation is essential to the final effect of a finish system, the apparatus shall be pre-cleaned with wax and grease remover and towel dried prior to evaporation.

A 10-step standard body preparation shall be completed.

When the substrate is prepared, the entire body shall be cleaned by washing again with wax and grease remover and towel dried.

PRETREAT AND PRIMERS:

The pretreat and primer applications shall be made in two (2) independent steps. A application of a combined pretreat/primer product will not be allowed as a substitute.

The prepared substrate shall be pretreated with Acid Curing 2 Component Transparent Primer. This pretreat shall be designed to provide corrosion protection and to create an adhesive bond between the substrate and the surface applications.

To enhance adhesion and top coat gloss, a 2 component epoxy primer shall be applied.

All the primed surfaces shall be sanded smooth, thus removing all texture and surface imperfections and creating a finish base that will meet the rigid requirements of the fire and emergency services.

TOP COATS:

Two (2) coats (0.5 - 2.0 mils) urethane base coat shall be applied in a professional manner. After the base coats have cured properly, two (2) coats of a high solids urethane clear coat shall be applied.

All surface imperfections shall be removed by buffing and polishing.

PAINT WARRANTY:

The apparatus shall be covered by a five (5) year paint warranty.

Following are the covered defects and exclusions.

Covered Defects shall include only the following list of defects:

- Peeling or delaminating of the topcoat and/or other layers of paint.
- Cracking or checking.
- Loss of gloss caused by cracking, checking or hazing.

Defects resulting from the following conditions are excluded from the Warranty:

- Hazing, chalking or loss of gloss caused by improper care, abrasive polishes, cleaning agents, heavy-duty pressure washing, or aggressive mechanical wash systems
- Rock chips are not covered under this warranty.
- Paint deteriorating caused by abuse, scratches, chips, gloss reduction, accidents, acid rain, chemical fallout or acts of nature
- Claims presented without proper Warranty documentation
- Failure on finishes performed by Non-PPG Commercial Certified Technicians
- Failures on finishes due to inadequate film builds
- Failures due to improper cleaning or surface preparation or failure to follow the product use instructions

ARMOUR SEAL BODY UNDERCOATING:

The apparatus body compartment area shall be undercoated with Armour Seal. Armour Seal is a spray on material allowing maximum surface area application for superior corrosion resistance. The material shall be applied to the body below the side and rear compartments. The benefits of Armour Seal include:

Meets tough environmental standards – low VOC'S - Volatile Organic Compounds, HAPS Free - No hazardous petroleum solvents, low odor and non-flammable!

Superior rust and corrosion protection – apply to new vehicles. Creates an abrasion resistant undercoating that blocks oxygen, stopping rust in its tracks!

Heavily tested – passes the Chloride Spray Test, exceeding 1000 hours. Plus, it meets the Military Spec TT-C-520 B Salt test!

The hose bed interior walls shall remain natural finish.

COMPARTMENT INTERIOR FINISH:

The interior of the compartments shall be natural finish aluminum

CAB LETTERING:

Vinyl lettering as described below shall be applied to the chassis cab door, one (1) each side. Each letter shall be 2½" to 3½" high and hand applied.

Vinyl letters/numbers shall be applied to the chassis cab fender area, one (1) each side. Each letter/number shall be 2½" to 3½" high and hand applied.

The lettering vinyl style shall be simulated gold leaf.

The lettering font style shall be Eurostile Bold.

The lettering font highlight type shall be shadow.

LAMINATION WARRANTY:

The apparatus shall be covered by a two (2) year warranty against defects in material and workmanship with the graphics process

REFLECTIVE STRIPING:

The finished apparatus shall be striped with 6" reflective Scotchlite striping.



The reflective striping shall be white in color.

"Z" STRIPE:

There shall be a "Z" design within the reflective striping on each side of the apparatus.

REFLECTIVE STRIPING IN THE CAB:

Two-inch red and white striped retro-reflective material shall be placed on the inside of each opening cab door. The material will be at least 96 square inches, meeting current NFPA standards.

DIAMOND GRADE CHEVRON STRIPING:

The rear of the apparatus shall be striped with Diamond Grade retro-reflective striping. The striping shall be applied in a chevron pattern sloping downward and away from the centerline of the apparatus at a 45° angle.

The Chevron striping shall be applied in the following locations: on the rear of the body and the rear of the tank.

The striping shall be single color alternating between red #3992 and fluorescent yellow-green #3983.

EQUIPMENT:

One (1) Duo-Safety #10-585A aluminum folding 10' attic ladder(s).

One (1) Duo-Safety 14-775A, 14' Roof Ladder(s) with hooks.

One (1) Duo-Safety #24-900A, 24' 2 Section ground ladder(s).

Two (2) 10' Length(s) of 6" diameter hard suction hose, coupled 6" LHF x 6" RLM. (Not rated for hydrants)

NFPA EQUIPMENT CLARIFICATION:

Any equipment specified in the "Minor Equipment" section (e.g. hose, nozzles, adapters, AED, traffic cones, traffic safety vests, etc.) of NFPA 1901 for each apparatus classification (see below) which is not specified in this proposal shall be considered to be customer supplied and installed.



 Alexis Fire Equipment
109 East Broadway / Alexis, IL 61412
 800-322-2284  sales@alexisfire.com
 AlexisFire.com

Apparatus Type	NFPA Section
Pumper	5.8
Initial Attack	6.7
Mobile Water Supply	7.7
Aerial	8.8
Quint	9.8
Special Service	10.5
Mobile Foam	11.9

VERTICAL CENTER OF GRAVITY / WEIGHT DISTRIBUTION

DWG NO. **P-AB67**

3/18/2024

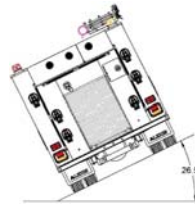
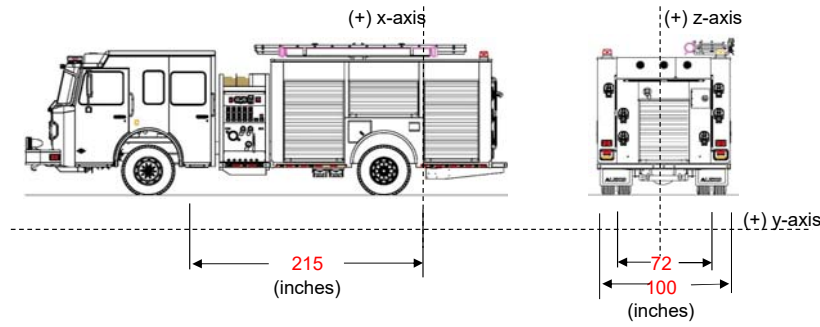

Contract No: **0**
 Proposal Name: **AFE Demo 2642**
 Calculated By: **M. Tinkham**
 Revision: **0**
 Type of Chassis: **International HV607 2-dr**
 Type of Pump: **Waterous CXVC20 1250g**
 Cab to Axle: **147.7**
 Tank Capacity: **2000**

Item	Weight (lbs)	Coordinates Local C.G. (in)			% Rear	Weight (lbs)		% Left	Right	Left
		z	x	y		Front	Rear			
Chassis	13501	0	135	42	37%	8496	5005	50%	6751	6751
Poly Tank (w/water)	18500	-3.3	19	77.4	91%	1635	16865	52%	8945	9555
Officer & Driver	500	0	171	66	20%	398	102	50%	250	250
Men & Equip.	0	0	0	0	0%	0	0	0%	0	0
Body Module	1791	0.00	17	42.81	92%	142	1650	50%	896	896
Subframe	580	0	17	39	92%	46	534	50%	290	290
Add. Equip. front	1364	0.00	64.75	42.2	70%	411	953	50%	682	682
Add. Equip. rear	636	0.00	-47.75	42.2	122%	-141	778	50%	318	318
Hose bed	1000	0	-2.7	111.5	101%	-13	1013	50%	500	500
Pump module	1173	0	121.88	61.35	43%	665	508	50%	587	587
Pump	1356	0	121.5	50.4	43%	766	590	50%	678	678
Dump	200	0	-80.25	49	137%	-75	275	50%	100	100
Suction Hose	120	-44.22	17	80	92%	9	111	72%	33	87
Ladders	185	44.5	17	79.7	92%	15	170	28%	134	51
Folding Tank	165	28.6	4.75	74.25	98%	4	161	36%	106	59
					0%			0%		
					0%			0%		
					0%			0%		
					0%			0%		
					0%			0%		
					0%			0%		
					0%			0%		
					0%			0%		
					0%			0%		
					0%			0%		
					0%			0%		
					0%			0%		
					0%			0%		
					0%			0%		
					0%			0%		
					0%			0%		
Total	41071.375	Global Center of Gravity				12357	28714		20269	20803
GAWR	46000	z	x	y		16000	30000			
Load as % of Total	100%	-1.3	64.7	61.2		30%	70%		49%	51%
						OK	OK		TRUE	

Truck Tipping Angle: **30** degrees (Full Water Tank) **OK**
 Maximum vertical center of gravity "z" = **57.60** **SC**
 (Maximum "z" is 80% of the rear axle track width)



HOSE CAPACITIES

DWG NO.

P-AB67

3/18/2024

Customer AFE Demo 2642
 Calculated By M. Tinkham

Contract No. 0
 Rev. No. 0

HOSE BED				Hose				
Length	126			Size	4			
Width	73			Amount	1000			
Height	13			DF	58	0	0	0
Cu. Ft.	69.20	0.00		Cu. Ft.	33.56	0.00	0.00	0.00
Total			69.20	Total				33.56
				Need				36.92

MATTYDALES				Hose			
Length	72	72	72	Size	2 1/2	1 3/4	1 3/4
Width	9.5	7	7	Amount	150	200	200
Height	14	14	14	DF	41	26	26
Cu. Ft.	5.54	4.08	4.08	Cu. Ft.	3.56	3.01	3.01
Total			13.71	Total			9.58

CARTRIDGE LAYS				Hose			
Length				Size			
Width				Amount			
Height				DF	0	0	0
Cu. Ft.	0.00	0.00	0.00	Cu. Ft.	0.00	0.00	0.00
Total			0.00	Total			0.00

HOSE TRAYS				Hose			
Length				Size			
Width				Amount			
Height				DF	0	0	0
Cu. Ft.	0.00	0.00	0.00	Cu. Ft.	0.00	0.00	0.00
Total			0.00	Total			0.00

HOSE WELLS				Hose			
Length				Size			
Width				Amount			
Height				DF	0	0	0
Cu. Ft.	0.00	0.00	0.00	Cu. Ft.	0.00	0.00	0.00
Total			0.00	Total			0.00

Standard Hose Dimensions per NFPA (2003 Edition)

1 3/4" lays 3 1/4" wide	DF=	26	1" FORESTRY lays 1 3/4" wide	DF=	10
2" lays 3 3/4" wide	DF=	32	1 1/2" FORESTRY 2 1/2" wide	DF=	14
2 1/2" lays 4 1/2" wide	DF=	41			
3" lays 5 1/4" wide	DF=	50			
4" lays 6 1/2" wide	DF=	58			
5" lays 8" wide - Angus	DF=	96			
5" lays 8-1/2" wide - Cotton	DF=	102			
6" lays 9 1/2" wide	DF=	108			

Prepared For:
ALEXIS FIRE EQUIPMENT
DIRK JORDAN
109 E Broadway Ave.
Alexis, IL 61412-5041
(309)335 - 0093
Reference ID: N/A

Presented By:
NEWLONS INTL SALES LLC
Beau Newlon
RT 250 S BEVERLY PIKE
PO BOX 134
ELKINS WV 26241 -
(304)636-4561

Thank you for the opportunity to provide you with the following quotation on a new International truck. I am sure the following detailed specification will meet your operational requirements, and I look forward to serving your business needs.

Model Profile
2025 HV607 SBA (HV607)

AXLE CONFIG:	4X2
APPLICATION:	Rescue
MISSION:	Requested GVWR: 37000. Calc. GVWR: 46000. Calc. GCWR: 80000 Calc. Start / Grade Ability: 36.92% / 5.48% @ 55 MPH Calc. Geared Speed: 67.5 MPH
DIMENSION:	Wheelbase: 215.00, CA: 147.90, Axle to Frame: 57.00
ENGINE, DIESEL:	{Cummins L9 450} EPA 2024, 450HP @ 2100 RPM, 1250 lb-ft Torque @ 1200 RPM, 2100 RPM Governed Speed, 450 Peak HP (Max), (RATED FOR EMERGENCY VEHICLES ONLY)
TRANSMISSION, AUTOMATIC:	{Allison 3000 EVS} 6th Generation Controls, Close Ratio, 5-Speed with Overdrive, with PTO Provision, Less Retarder, Includes Oil Level Sensor, Max, GVW N/A
CLUTCH:	Omit Item (Clutch & Control)
AXLE, FRONT NON-DRIVING:	{Meritor MFS-16-143A} Wide Track, I-Beam Type, 16,000-lb Capacity
AXLE, REAR, SINGLE:	{Meritor RS-30-185} Single Reduction, 30,000-lb Capacity, Driver Controlled Locking Differential, T Wheel Ends Gear Ratio: 5.38
CAB:	Conventional, Day Cab
TIRE, FRONT:	(2) 315/80R22.5 Load Range L X WORKS Z (MICHELIN), 485 rev/mile, 68 MPH, All-Position
TIRE, REAR:	(4) 315/80R22.5 Load Range L X WORKS Z (MICHELIN), 485 rev/mile, 68 MPH, All-Position
SUSPENSION, REAR, SINGLE:	31,000-lb Capacity, Vari-Rate Springs, with 4500-lb Capacity Auxiliary Multileaf Springs
FRAME REINFORCEMENT:	Full Outer C-Channel, Heat Treated Alloy Steel (120,000 PSI Yield), 10.813" x 3.892" x 0.312" (274.6mm x 98.8mm x 7.9mm), 480.0" (12192mm) OAL
PAINT:	Cab schematic 100WL Location 1: 2303, Red (Std) Chassis schematic N/A

<u>Code</u>	<u>Description</u>	<u>F/R Wt</u> (lbs)	<u>Tot Wt</u> (lbs)
HV60700	Base Chassis, Model HV607 SBA with 215.00 Wheelbase, 147.90 CA, and 57.00 Axle to Frame.	6136/3644	9780

AXLE CONFIGURATION

1ANA	AXLE CONFIGURATION {Navistar} 4x2	-52/-83	-135
	<u>Notes</u> : Pricing may change if axle configuration is changed.		

ENGINE

12EZE	ENGINE, DIESEL {Cummins L9 450} EPA 2024, 450HP @ 2100 RPM, 1250 lb-ft Torque @ 1200 RPM, 2100 RPM Governed Speed, 450 Peak HP (Max), (RATED FOR EMERGENCY VEHICLES ONLY)	580/-16	564
12VJS	EMISSION, CALENDAR YEAR {Cummins L9} EPA, OBD and GHG Certified for Calendar Year 2024	0/0	0
12XCS	CARB EMISSION WARR COMPLIANCE Does Not Comply with CARB Emission Warranty	0/0	0
12WZE	CARB IDLE COMPLIANCE Does Not Comply with California Clean Air Idle Regulations	0/0	0
12WVG	EPA IDLE COMPLIANCE Low NOx Idle Engine, Complies with EPA Clean Air Regulations; Includes "Certified Clean Idle" Decal on Hood	0/0	0
12UYH	RADIATOR Aluminum, Cross Flow, Front to Back System, 1469 SqIn, with 1172 SqIn Charge Air Cooler	-48/1	-47
	<u>Includes</u> : DEAERATION SYSTEM with Surge Tank : HOSE CLAMPS, RADIATOR HOSES Gates Shrink Band Type; Thermoplastic Coolant Hose Clamps : RADIATOR HOSES Premium, Rubber		
12THT	FAN DRIVE {Horton Drivemaster} Two-Speed Type, Direct Drive, with Residual Torque Device for Disengaged Fan Speed	0/0	0
	<u>Includes</u> : FAN Nylon		
12VBC	AIR CLEANER Single Element	0/0	0
12703	ANTI-FREEZE Red, Extended Life Coolant; To -40 Degrees F/ -40 Degrees C, Freeze Protection	0/0	0
12XBM	ENGINE CONTROL, REMOTE MOUNTED Provision for; Includes Wiring for Body Builder Installation of PTO Controls and Starter Lockout, with Ignition Switch Control, for Cummins B6.7 and L9 Engines	0/0	0
12VXT	THROTTLE, HAND CONTROL Engine Speed Control; Electronic, Stationary, Variable Speed; Mounted on Steering Wheel	0/0	0

TRANSMISSION

13BCT	TRANSMISSION, AUTOMATIC {Allison 3000 EVS} 6th Generation Controls, Close Ratio, 5-Speed with Overdrive, with PTO Provision, Less Retarder, Includes Oil Level Sensor, Max, GVW N/A	230/53	283
-------	---	--------	-----

<u>Code</u>	<u>Description</u>	<u>F/R Wt</u> (lbs)	<u>Tot Wt</u> (lbs)
13WUD	ALLISON SPARE INPUT/OUTPUT for Emergency Vehicle Series (EVS), Rescue, Ambulance, Package Number 170	0/0	0
13WAW	OIL COOLER, TRANSMISSION {Modine} Water to Oil Type	25/0	25
13XAL	PTO LOCATION Customer Intends to Install PTO at Left Side of Transmission	0/0	0
13WYU	SHIFT CONTROL PARAMETERS {Allison} 3000 or 4000 Series Transmissions, Performance Programming	0/0	0
13WLP	TRANSMISSION OIL Synthetic; 29 thru 42 Pints	0/0	0
13WET	TRANSMISSION SHIFT CONTROL Column Mounted Stalk Shifter, Not for Use with Allison 1000 & 2000 Series Transmission	1/0	1

CLUTCH

11001	CLUTCH Omit Item (Clutch & Control)	0/0	0
-------	-------------------------------------	-----	---

REAR AXLES, SUSPENSIONS

14ASD	AXLE, REAR, SINGLE {Meritor RS-30-185} Single Reduction, 30,000-lb Capacity, Driver Controlled Locking Differential, T Wheel Ends . Gear Ratio: 5.38 <u>Notes</u> : Axle Lead Time is 60 Days	0/307	307
14SAL	SUSPENSION, REAR, SINGLE 31,000-lb Capacity, Vari-Rate Springs, with 4500-lb Capacity Auxiliary Multileaf Springs	0/177	177

FRONT AXLES

2ARU	AXLE, FRONT NON-DRIVING {Meritor MFS-16-143A} Wide Track, I-Beam Type, 16,000-lb Capacity	148/0	148
------	---	-------	-----

FRONT SUSPENSIONS

3ADE	SUSPENSION, FRONT, SPRING Parabolic Taper Leaf, Shackle Type, 16,000-lb Capacity, with Shock Absorbers	44/0	44
------	--	------	----

CABS, COWLS, BODIES

16030	CAB Conventional, Day Cab	0/0	0
16XTK	ACCESS, CAB Bright Aluminum, Driver & Passenger Sides, Two Steps per Door, for use with Day Cab or Extended Cab	-14/-2	-16
16BAM	AIR CONDITIONER with Integral Heater and Defroster	0/0	0
16VKB	CAB INTERIOR TRIM Classic, for Day Cab <u>Includes</u> : CONSOLE, OVERHEAD Molded Plastic with Dual Storage Pockets, Retainer Nets and CB Radio Pocket; Located Above Driver and Passenger : DOME LIGHT, CAB Door Activated and Push On-Off at Light Lens, Timed Theater Dimming, Integral to Overhead Console, Center Mounted : SUN VISOR (2) Padded Vinyl; 2 Moveable (Front-to-Side) Primary Visors, Driver Side with Toll Ticket Strap	0/0	0
16VHX	CAB MOUNTING HEIGHT EFFECTS High Cab in Lieu of Mid High Cab Mounting (Approx. 4.5")	0/0	0

<u>Code</u>	<u>Description</u>	<u>F/R Wt</u> (lbs)	<u>Tot Wt</u> (lbs)
16WSK	CAB REAR SUSPENSION Air Bag Type	0/0	0
16GED	GAUGE CLUSTER Base Level; English with English Electronic Speedometer <u>Includes</u> : GAUGE CLUSTER DISPLAY: Base Level (3" Monochromatic Display), Premium Level (5" LCD Color Display); Odometer, Voltmeter, Diagnostic Messages, Gear Indicator, Trip Odometer, Total Engine Hours, Trip Hours, MPG, Distance to Empty/ Refill for : GAUGE CLUSTER Speedometer, Tachometer, Engine Coolant Temp, Fuel Gauge, DEF Gauge, Oil Pressure Gauge, Primary and Secondary Air Pressure : WARNING SYSTEM Low Fuel, Low DEF, Low Oil Pressure, High Engine Coolant Temp, Low Battery Voltage (Visual and Audible), Low Air Pressure (Primary and Secondary)	0/0	0
16HHE	GAUGE, AIR CLEANER RESTRICTION {Filter-Minder} Mounted in Instrument Panel	2/0	2
16HGH	GAUGE, OIL TEMP, AUTO TRANS for Allison Transmission	1/0	1
16XJN	INSTRUMENT PANEL Flat Panel	0/0	0
16HKT	IP CLUSTER DISPLAY On Board Diagnostics Display of Fault Codes in Gauge Cluster	0/0	0
16SNU	MIRRORS (2) Aero Pedestal, Power Adjust, Heated, Bright Heads, Black Arms, 6.5" x 14" Flat Glass, Includes 6.5" x 6" Convex Mirrors, for 102" Load Width <u>Notes</u> : Mirror Dimensions are Rounded to the Nearest 0.5"	0/0	0
16VLV	MONITOR, TIRE PRESSURE Omit	-10/-1	-11
16VBZ	SEAT BELT All Red; 1 to 3	0/0	0
16JJE	SEAT, DRIVER {National 2000} NFPA Compliant, Air Suspension, High Back with Integral Headrest, Vinyl, Isolator, 1 Chamber Lumbar, 2 Position Front Cushion Adjust, -3 to +14 Degree Back Angle Adjust	1/0	1
16PPG	SEAT, PASSENGER {National 2000} NFPA Compliant, Air Suspension, High Back with Integral Headrest, Vinyl, Isolator, 1 Chamber Lumbar, 2 Position Front Cushion Adjustment, -3 to +14 Degree Back Angle Adjust	60/36	96
16HCK	SEATBELT WARNING PREWIRE Includes Seat Belt Switches and Seat Sensors for all Belted Positions in the Cab and a Harness Routed to the Center of the Dash for the Aftermarket Installation of the Data Recorder and Seatbelt Indicator Systems, for 1 to 3 Seat Belts	0/0	0
16WJU	WINDOW, POWER (2) and Power Door Locks, Left and Right Doors, Includes Express Down Feature	0/0	0
FRAMES			
1CBU	FRAME RAILS Heat Treated Alloy Steel (120,000 PSI Yield); 10.125" x 3.580" x 0.312" (257.2mm x 90.9mm x 8.0mm); 480.0" (12192) Maximum OAL	93/205	298
1GBP	FRAME REINFORCEMENT Full Outer C-Channel, Heat Treated Alloy Steel (120,000 PSI Yield), 10.813" x 3.892" x 0.312" (274.6mm x 98.8mm x 7.9mm), 480.0" (12192mm) OAL	452/535	987
1MDP	BUMPER, FRONT Contoured, Stainless Steel, Polished	-21/3	-18
1570	TOW HOOK, FRONT (2) Frame Mounted	8/0	8

<u>Code</u>	<u>Description</u>	<u>F/R Wt</u> (lbs)	<u>Tot Wt</u> (lbs)
1WGS	WHEELBASE RANGE 189" (480cm) Through and Including 256" (650cm)	271/-271	0
BRAKES			
4091	BRAKE SYSTEM, AIR Dual System for Straight Truck Applications <u>Includes</u> : BRAKE LINES Color and Size Coded Nylon : DRAIN VALVE Twist-Type : GAUGE, AIR PRESSURE (2) Air 1 and Air 2 Gauges; Located in Instrument Cluster : PARKING BRAKE CONTROL Yellow Knob, Located on Instrument Panel : PARKING BRAKE VALVE For Truck : QUICK RELEASE VALVE On Rear Axle for Spring Brake Release: 1 for 4x2, 2 for 6x4 : SPRING BRAKE MODULATOR VALVE R-7 for 4x2, SR-7 with relay valve for 6x4/8x6	0/0	0
4AZS	AIR BRAKE ABS {Bendix AntiLock Brake System} 4-Channel (4 Sensor/4 Modulator) Electronic Stability Program, with Automatic Traction Control	6/2	8
4GBM	BRAKE, PARKING Manual Push-Pull Pneumatic Parking Brake	1/0	1
4XDT	BRAKES, FRONT {Meritor 16.5X6 Q-PLUS CAST} Air S-Cam Type, Cast Spider, Fabricated Shoe, Double Anchor Pin, Size 16.5" X 6", 23,000-lb Capacity	33/0	33
4EXV	BRAKE CHAMBERS, FRONT AXLE {Bendix} 24 SqIn	4/0	4
4LAG	SLACK ADJUSTERS, FRONT {Gunite} Automatic	14/0	14
4WBX	DUST SHIELDS, FRONT BRAKE for Air Cam Brakes	10/0	10
4XCZ	BRAKES, REAR {Meritor 16.5X7 P} Air S-Cam Type, Cast Spider, Cast Shoe, Double Anchor Pin, Includes Greaseable and Zinc Coated Anchor Pins, Size 16.5" X 7", 38,000-lb Capacity per Axle	0/106	106
4EVH	BRAKE CHAMBERS, REAR AXLE {MGM TR3030LP3TSHD} 30/30 SqIn Spring Brake	0/9	9
4LGG	SLACK ADJUSTERS, REAR {Gunite} Automatic	0/14	14
4WDM	DUST SHIELDS, REAR BRAKE for Air Cam Brakes	0/10	10
4SPA	AIR COMPRESSOR {Cummins} 18.7 CFM	0/0	0
4EBS	AIR DRYER {Bendix AD-9} with Heater	19/9	28
4VKC	AIR DRYER LOCATION Mounted Inside Left Rail, Back of Cab	15/6	21
4VGN	AIR TANK Painted Aluminum, with Straight Thread O-Ring Ports	-13/-3	-16
4WZJ	AIR TANK LOCATION (2) : One Mounted Under Each Rail, Front of Rear Suspension, Parallel to Rail	-26/45	19
4732	DRAIN VALVE {Berg} with Pull Chain, for Air Tank	0/0	0
STEERING			
5PTB	STEERING GEAR (2) {Sheppard M100/M80} Dual Power	101/-5	96
5708	STEERING COLUMN Tilting	14/1	15
5CAW	STEERING WHEEL 4-Spoke; 18" Dia., Black	0/0	0

<u>Code</u>	<u>Description</u>	<u>F/R Wt</u> (lbs)	<u>Tot Wt</u> (lbs)
DRIVELINES			
6DGC	DRIVELINE SYSTEM {Dana Spicer} SPL170, for 4x2/6x2	6/32	38
EXHAUST SYSTEMS			
7BLW	EXHAUST SYSTEM Horizontal Aftertreatment System, Frame Mounted Right Side Under Cab, for Single Vertical Tail Pipe, Frame Mounted Right Side Back of Cab	142/35	177
7BES	AFTERTREATMENT COVER Polished Aluminum	9/2	11
7SDP	ENGINE COMPRESSION BRAKE {Jacobs} for Cummins ISL/L9 Engines; with Selector Switch and On/Off Switch	43/5	48
7WDM	EXHAUST HEIGHT 10'	19/9	28
7WBS	MUFFLER/TAIL PIPE GUARD (1) Bright Stainless Steel	16/9	25
7WZX	SWITCH, FOR EXHAUST 3 Position, Momentary, Lighted Momentary, ON/ CANCEL, Center Stable, INHIBIT REGEN, Mounted in IP Inhibits Diesel Particulate Filter Regeneration When Switch is Moved to ON While Engine is Running, Resets When Ignition is Turned OFF	2/0	2
7WBA	TAIL PIPE (1) Turnback Type, Bright	6/3	9
ELECTRICAL SYSTEMS			
8000	ELECTRICAL SYSTEM 12-Volt, Standard Equipment <u>Includes</u> : DATA LINK CONNECTOR For Vehicle Programming and Diagnostics In Cab : HAZARD SWITCH Push On/Push Off, Located on Instrument Panel to Right of Steering Wheel : HEADLIGHT DIMMER SWITCH Integral with Turn Signal Lever : PARKING LIGHT Integral with Front Turn Signal and Rear Tail Light : STARTER SWITCH Electric, Key Operated : STOP, TURN, TAIL & B/U LIGHTS Dual, Rear, Combination with Reflector : TURN SIGNAL SWITCH Self-Cancelling for Trucks, Manual Cancelling for Tractors, with Lane Change Feature : WINDSHIELD WIPER SWITCH 2-Speed with Wash and Intermittent Feature (5 Pre-Set Delays), Integral with Turn Signal Lever : WINDSHIELD WIPERS Single Motor, Electric, Cowl Mounted : WIRING, CHASSIS Color Coded and Continuously Numbered	0/0	0
8GXX	ALTERNATOR {Leece-Neville BLP4006HN} Brushless, 12 Volt, 325 Amp Capacity, Pad Mount, with Remote Sense	17/0	17
8RPP	ANTENNA Shark Fin, Roof Mounted	1/0	1
8THB	BACK-UP ALARM Electric, 102 dBA	0/3	3
8XDU	BATTERY BOX Steel, with Aluminum Cover, 14" Wide, 2-3 Battery Capacity, Mounted Left Side Under Cab	-11/5	-6
8MJU	BATTERY SYSTEM {Fleetrite} Maintenance-Free, (3) 12-Volt 2850CCA Total, Top Threaded Stud	43/31	74
8HAB	BODY BUILDER WIRING Back of Day Cab at Left Frame or Under Sleeper, Extended or Crew Cab at Left Frame; Includes Sealed Connectors for Tail/Amber Turn/Marker/ Backup/Accessory Power/Ground and Sealed Connector for Stop/ Turn	2/0	2

<u>Code</u>	<u>Description</u>	<u>F/R Wt</u> (lbs)	<u>Tot Wt</u> (lbs)
8XAH	CIRCUIT BREAKERS Manual-Reset (Main Panel) SAE Type III with Trip Indicators, Replaces All Fuses	0/0	0
8518	CIGAR LIGHTER Includes Ash Cup	1/0	1
8WPH	CLEARANCE/MARKER LIGHTS (5) {Truck Lite} Amber LED Lights, Flush Mounted on Cab or Sunshade	0/0	0
8TPA	DATA RECORDER Includes Display Mounted in Overhead Console	2/0	2
8XNZ	HEADLIGHTS Halogen, with Daytime Running Lights	0/0	0
8WHE	HORN, AIR Accommodation Package, Less Horn	2/0	2
8VAY	HORN, ELECTRIC Disc Style	0/0	0
8WWJ	INDICATOR, LOW COOLANT LEVEL with Audible Alarm	0/0	0
8RPT	RADIO AM/FM/WB/Clock/USB Input/Auxiliary Input	3/0	3
8RMZ	SPEAKERS (2) 6.5" Dual Cone Mounted in Both Doors, (2) 5.25" Dual Cone Mounted in Both B-Pillars	6/2	8
8WXG	STARTING MOTOR {Mitsubishi Electric Automotive America 105P} 12-Volt, with Soft-Start	10/0	10
8VTV	STOP-LIGHT WIRING MODIFIED Stop-Lights Turned on When Engine Compression Brake, Exhaust Brake or Retarder is Activated	0/0	0
8XKM	SWITCH, AIR HORN, PASSENGER Fire Truck Application; Momentary Switch Located in Instrument Panel Close to Passenger, Driver Also To Activate Switch with Lanyard	0/0	0
8WPZ	TEST EXTERIOR LIGHTS Pre-Trip Inspection will Cycle all Exterior Lamps Except Back-up Lights	0/0	0
8XGT	TURN SIGNALS, FRONT Includes LED Side Turn Lights Mounted on Fender	0/0	0
8XPP	USB PORT Two USB-A Ports and Two USB-C Ports, Located in Instrument Panel	0/0	0
8WGL	WINDSHIELD WIPER SPD CONTROL Force Wipers to Slowest Intermittent Speed When Park Brake Set and Wipers Left on for a Predetermined Time	0/0	0

FRONT END

9WBC	FRONT END Tilting, Fiberglass, with Three Piece Construction, for WorkStar/HV	0/0	0
9WAC	BUG SCREEN Mounted Behind Grille	5/0	5
9585	FENDER EXTENSIONS Rubber	6/0	6
9HBM	GRILLE Stationary, Chrome	0/0	0
9WBT	GRILLE EMBER SCREEN Mounted to Grille and Cowl Tray to Keep Hot Embers out of Engine and HVAC Air Intake System	3/0	3
9HAN	INSULATION, UNDER HOOD for Sound Abatement	10/0	10
9AAB	LOGOS EXTERIOR Model Badges	0/0	0
9AAE	LOGOS EXTERIOR, ENGINE Badges	0/0	0

SPEEDOMETER, TOOLS, MISC

<u>Code</u>	<u>Description</u>	<u>F/R Wt</u> (lbs)	<u>Tot Wt</u> (lbs)
10AGB	COMMUNICATIONS MODULE Telematics Device with Over the Air Programming; Includes Five Year Data Plan and International 360	1/0	1
10060	PAINT SCHEMATIC, PT-1 Single Color, Design 100 <u>Includes</u> : PAINT SCHEMATIC ID LETTERS "WL"	0/0	0
10761	PAINT TYPE Base Coat/Clear Coat, 1-2 Tone	0/0	0

FUEL TANKS

15SXX	FUEL TANK Top Draw, Polished Aluminum, 24" Dia, 50 US Gal (189L), Mounted Left Side, Under Cab	31/3	34
15WCN	DEF TANK 5 US Gal (19L) Capacity, Frame Mounted Outside Left Rail, Under Cab	2/15	17
15924	FUEL TANK STRAPS Bright Finish Stainless Steel	0/0	0
15LNS	FUEL/WATER SEPARATOR {Racor 400 Series} 12 VDC Electric Heater, Includes Pre-Heater, with Primer Pump, Includes Water-in-Fuel Sensor, Mounted on Engine	-2/-3	-5

WHEELS, TIRES - FRONT

27DUS	WHEELS, FRONT {Accuride 41730} DISC; 22.5x9.00 Rims, Extra Polish Aluminum, 10-Stud, 285.75mm BC, Hub-Piloted, Flanged Nut, with Steel Hubs	-28/0	-28
7652543287	(2) TIRE, FRONT 315/80R22.5 Load Range L X WORKS Z (MICHELIN), 485 rev/mile, 68 MPH, All-Position	64/0	64

WHEELS, TIRES - REAR

28DUS	WHEELS, REAR {Accuride 41730} DUAL DISC; 22.5x9.00 Rims, Extra Polish Aluminum, 10-Stud, 285.75mm BC, Hub-Piloted, Flanged Nut, with Steel Hubs	0/-56	-56
7652543287	(4) TIRE, REAR 315/80R22.5 Load Range L X WORKS Z (MICHELIN), 485 rev/mile, 68 MPH, All-Position	0/128	128

WHEELS MISC OPTIONS

29PBT	COATING IDENTITY, FRONT WHEELS {Accuride Accu-Shield} Disc Front Wheels, Aluminum, with Vendor Applied Clear Coat, Not for Wide Base	0/0	0
29PBS	COATING IDENTITY, REAR WHEELS {Accuride Accu-Shield} Disc Rear Wheels, Aluminum, with Vendor Applied Clear Coat, Not for Super Single/Wide Base	0/0	0

Services Section:**WARRANTY**

40128	WARRANTY Standard for HV507, HV50B, HV607 Models, Effective with Vehicles Built July 1, 2017 or Later, CTS-2025A	0/0	0
	Total Component Weight:	8496/5005 (lbs)	13501 (lbs)
1	HOOD MOUNTED AIR HORNS (FIRE TRUCK)	0/0	0
	Total Body Allied:	0/0 (lbs)	0 (lbs)

The weight calculations included in this proposal are an estimate of future vehicle weight. The actual weight as manufactured may be different from the estimated weight. Navistar, Inc. shall not be liable for any consequences resulting from any differences between the estimated weight of a vehicle and the actual weight.

<u>Description</u>	<u>(US DOLLAR)</u>	<u>Price</u>
Factory List Prices:		
Product Items	\$182,401.00	
Service Items	\$0.00	
Total Factory List Price Including Options:		\$182,401.00
Freight	\$3,100.00	
Total Freight:		\$3,100.00
Total Factory List Price Including Freight:		\$185,501.00
Less Customer Allowance:		(\$59,701.00)
Total Vehicle Price:		\$125,800.00
Total Body/Allied Equipment:		\$850.00
Total Sale Price:		\$126,650.00
Total Per Vehicle Sales Price:		\$126,650.00
Net Sales Price:		\$126,650.00

Please feel free to contact me regarding these specifications should your interests or needs change. I am confident you will be pleased with the quality and service of an International vehicle.

Approved by Seller:

Accepted by Purchaser:

Official Title and Date

Firm or Business Name

Authorized Signature

Authorized Signature and Date

This proposal is not binding upon the seller without Seller's Authorized Signature

Official Title and Date

The TOPS FET calculation is an estimate for reference purposes only. The seller or retailer is responsible for calculating and reporting/paying appropriate FET to the IRS.

The limited warranties applicable to the vehicles described herein are Navistar, Inc.'s standard printed warranties which are incorporated herein by reference and to which you have been provided a copy and hereby agree to their terms and conditions.